



Instruction Manual

GAS ANALYZER FOR HEAT TREATMENT FURNACES

TYPE: ZFG



PREFACE

We are grateful for your purchase of Fuji Gas Analyzer for Heat Treatment Furnaces, TYPE: ZFG.

- First read this instruction manual carefully until an adequate understanding is acquired, and then proceed to installation, operation and maintenance of the analyzer. Wrong handling may cause an accident or injury.
- The specifications of this analyzer are subject to change without prior notice for further product improvement.
- Modification of this analyzer is strictly prohibited unless a written approval is obtained from the manufacturer. Fuji Electric will not bear any responsibility for a trouble caused by such a modification.
- This instruction manual shall be stored by the person who actually uses the analyzer.
- After reading the manual, be sure to store it at a place easier to access.
- This instruction manual should be delivered to the end user without fail.

Manufacturer: Fuji Electric Co., Ltd.
Type: Described in the nameplate on main frame
Date of manufacture: Described in the nameplate on main frame
Product nationality: Japan

Request

- It is prohibited to transfer part or all of this manual without Fuji Electric's permission in written format.
- Description in this manual is subject to change without prior notice for further improvement.



© Fuji Electric Co., Ltd. 2018

Issued in March, 2018



CAUTION ON SAFETY

First of all, read this “Caution on safety” carefully, and then use the analyzer in the correct way.

- The cautionary descriptions listed here contain important information about safety, so they should always be observed. Those safety precautions are ranked in 3 levels, “DANGER,” “CAUTION” and “PROHIBITION.”

 DANGER	Wrong handling may cause a dangerous situation, in which there is a risk of death or heavy injury.
 CAUTION	Wrong handling may invite a dangerous situation, in which there is a possibility of medium-level trouble or slight injury or only physical damage is predictable.
 PROHIBITION	Items which must not be done are noted.

Caution on installation, transport and storage of gas analyzer

 DANGER	<ul style="list-style-type: none"> This unit is not explosion-proof type. Do not use it in a place with explosive gases to prevent explosion, fire or other serious accidents.
 CAUTION	<ul style="list-style-type: none"> The gas analyzer is heavy. It should be installed with utmost care. Otherwise, it may tip over or drop, for example, causing accident or injury. This unit should be installed in a place which conforms to the conditions noted in the instruction manual. Otherwise, it may cause electric shocks, fire or malfunction of the unit. During installation work, care should be taken to keep the unit free from entry of cable chips or other foreign objects. Otherwise, it may cause fire, trouble or malfunction of the unit.

Caution on piping



Be sure to observe the following precautions while installing piping. Improper piping may result in gas leakage.

If the leaking gas contains a toxic component, serious accidents may result. If it contains combustible gases, explosion or fire may result.

- Connect pipes correctly referring to the instruction manual.
- Discharge the exhaust gas outdoors to prevent it from remaining within doors.
- Relieve the exhaust gas from the analyzer to the atmospheric pressure to prevent buildup of undesirable pressure to the analyzer. Otherwise piping within the analyzer may be disconnected, resulting in gas leakage.
- Use material to which no oil/grease is attached for piping. Otherwise, fire may result.

Caution on wiring



- Be sure to turn off all the power before installing wiring. Otherwise electric shock may result.
- Be sure to perform class D grounding work. Otherwise, electric shock or failure may result.
- Select a proper wiring material that satisfies the ratings of the instrument. Otherwise, electric shock or fire may result.
- Be sure to connect a power supply of correct rating. Otherwise, fire may result.

Caution on use



- If unusual smell or sound has been produced, immediately stop the instrument. Any discharge produced may cause a fire.



- Leaving the analyzer unused for a long time or restarting it after long-term suspension requires procedures different from normal operation or suspension procedures. Be sure to follow the instructions in each instruction manual. Otherwise, intended performance may not be achieved, or accidents or injury may result.
- Do not operate the analyzer for a long time with its door left open. Otherwise, dust, foreign matter, etc. may stick on internal walls, thereby causing faults.

Caution on use



- Do not allow metal, finger or others to touch the power and input/output terminal blocks in the instrument. Otherwise, faults, electric shock or injuries may be caused.
- Do not smoke nor use a flame near the gas analyzer. Otherwise, a fire may be caused.

Caution on maintenance and check



- For correct handling of calibration gas or other reference gases, carefully read their instruction manuals beforehand. Otherwise, carbon monoxide or other hazardous gases may cause an intoxication particularly.
- Before performing work for maintenance and check, be sure to purge completely not only within the analyzer but also measuring gas lines with nitrogen or air. Otherwise, poisoning, fire, or explosion may result due to gas leakage.
- Before replacing the gas filter of the gas analyzer or maintaining the washer, close the calibration gas valve and, if provided, the valve on the sample gas suction port. Otherwise, intoxication or accident may occur.



- If the fuse is blown, eliminate the cause, and then replace it with the one of the same capacity and type as before. Otherwise, shock hazard or fault may be caused.
 - Do not use a replacement part other than specified by the instrument maker. Otherwise, adequate performance will not be provided. Besides, an accident or fault may be caused.
 - Replacement parts such as a maintenance part should be disposed of as incombustibles. For details, follow the local ordinance.
- Be sure to observe the following for safe operation to prevent the shock hazard and injury.**
- Remove the watch and other metallic objects before work.
 - Do not touch the instrument wet-handed.

Others



- If the cause of any fault cannot be determined despite reference to the instruction manual, be sure to contact your dealer or Fuji Electric's technician in charge of adjustment. If the instrument is disassembled carelessly, you may have a shock hazard or injury.

WARRANTY AND MAINTENANCE

1. Scope of application

To use this equipment, the following conditions must be met:

- the use of the equipment incurs no risk of a serious accident even if a failure or malfunction occurs on the equipment, and
- in case of product failure or malfunction, safety measures such as redundant design, prevention of malfunction, fail safe system, foolproof mechanism are provided outside of the equipment.

Be sure to use this instrument under the conditions or environment mentioned in this instruction manual. Please consult us for specifications for the following applications:

Radiation-related facilities, systems related to charging or settlement, or other usages which may have large impact on lives, bodies, property, or other rights or interests.

2. Operating conditions and environment

Refer to "Caution on Safety" and Chapter 7, "Specifications".

3. Precautions and prohibitions

Refer to "Caution on Safety" and Chapter 7, "Specifications".

4. Warranty

4-1. Period of warranty

- (1) Warranty period for this product including accessories is one year after delivery.
- (2) Warranty period for the parts repaired by our service providers is six months after the completion of repair.

4-2. Scope of warranty

- (1) If any failure or malfunction attributable to Fuji Electric occurs in the period of warranty, we shall provide the product after repairing or replacing the faulty part for free of charge at the place of purchase or delivery.

The warranty does not apply to failure or malfunctions resulting from:

- a) inappropriate conditions, environment, handling or usage that is not instructed in a catalog, instruction book or user's manual, or overuse of the product
 - b) other devices not manufactured by Fuji Electric
 - c) improper use, or an alteration or repair that is not performed by Fuji Electric
 - d) inappropriate maintenance or replacement of expendable parts listed in the instruction book or the catalog
 - e) damages incurred during transportation or fall after purchase
 - f) any reason that Fuji Electric is not responsible for, including a disaster or natural disaster such as earthquake, thunder, storm and flood damage, or inevitable accident such as abnormal voltage.
- (2) Regardless of the time period of the occurrence, Fuji Electric is not liable for the damage caused by the factors Fuji Electric is not responsible for, opportunity loss of the purchaser caused by malfunction of Fuji Electric product, passive damages, damage caused due to special situations regardless of whether it was foreseeable or not, and secondary damage, accident compensation, damage to products that were not manufactured by Fuji Electric, and compensation towards other operations.

5. Failure diagnosis

Regardless of the time period of the occurrence, if any failure occurs, the purchaser shall perform a primary failure diagnosis. However, at the purchaser's request, Fuji Electric shall provide the diagnosis service for a fee. In such a case, the purchaser shall be charged for the service.

6. Service life

This product, excluding limited-life parts and consumable parts, is designed for a service life of 10 years under a general condition (average ambient temperature of 30°C).

The service life may be shortened depending on operating conditions and environment. To ensure the service life, it is important to perform planned maintenance of the product including limited-life parts and consumable parts.

7. Maintenance plan

Maintenance can be divided into "preventive maintenance" and "corrective maintenance". Preventive maintenance can further be classified into "daily inspection" and "periodic inspection". Preventive maintenance is achieved through systematic implementation of "daily inspection" and "periodic inspection".

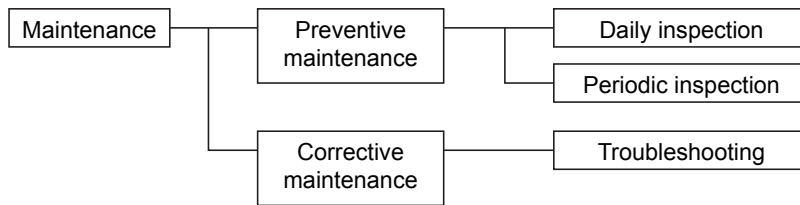

(1) Daily inspection

Be sure to perform daily inspection prior to operation to check for any problem in daily operation. For the specific items of daily inspection, refer to Chapter 5, "Maintenance".

(2) Periodic inspection

Periodic inspection is to replace limited-life parts before their service lives are over, thus preventing failure. Inspection interval: 6 months to 12 months. If you are using the instrument under harsh environment, we recommend you to shorten the inspection interval. For the specific items of periodic inspection, refer to Chapter 5, "Maintenance".

(3) Corrective maintenance

Corrective maintenance is a measure to be taken after a trouble has occurred. Refer to Chapter 5, "Maintenance" and Chapter 6, "Error message". If the measures mentioned in this instruction manual do not solve the problem, please contact our sales office or service office.

8. Limited-life parts and consumable parts

This product contains the following limited-life parts and consumable parts which may affect the service life of the product itself.

(1) Aluminum electrolytic capacitors

- Design life: 5 years under general working conditions (annual average of ambient temperature: 30°C)
- Symptoms when a capacitor loses its capacity: deterioration of power quality, malfunction
- Factors which affect capacitor life: temperature. The life is shortened by half when the temperature rises by 10°C. (Arrhenius' law)

- Replacement: Estimate the lifetime of capacitor according to your operating environment, and have the capacitor replaced or overhauled at appropriate time, at least once in 10 years.

Do not use capacitors beyond its lifetime. Otherwise, electrolyte leakage or depletion may cause odor, smoke, or fire. Please contact Fuji Electric or its service providers when an overhaul is required.

(2) LCD

- Design life: approx. three years for continuous use
- Symptoms when LCD is depleted: unclear indication, back light not working.
- Factors which affect battery life: temperature. The life is shortened by half when the temperature rises by 10°C. (Arrhenius' law)
- Replacement: Estimate the lifetime of built-in battery according to your operating environment, and replaced it at appropriate time.

9. Spare parts and accessories

Refer to "Confirmation of delivered equipment" and/or Chapter 5, "Maintenance" for spare parts and accessories.

10. Period for repair and provision of spare parts after product discontinuation (maintenance period)

The discontinued models (products) can be repaired for five years from the date of discontinuation. Also, most spare parts used for repair are provided for five years from the date of discontinuation. However, some electric parts may not be obtained due to their short life cycle. In this case, repair or provision of spare parts may be difficult even in the above period.

Please contact one of our sales offices or service offices for further information.

Checking of contents of the package

- Check that all of the following are contained in the delivered package.
 - (1) Analyzer main unit
 - (2) Standard accessories (See “Table 1 Standard accessories.”)

Table 1 Standard accessories

No.	Name	Q'ty	Note
1	Tubular fuse (1A)	2	(100V to 250V AC)
2	Mounting fixture	2	
3	Instruction manual (English)	1	INZ-TN3ZFG-E

- (3) Auxiliary mounting plate (as specified by option)

CONTENTS

PREFACE.....	i
CAUTION ON SAFETY	ii
WARRANTY AND MAINTENANCE.....	v
Checking of contents of the package.....	viii
1. OVERVIEW	1
1.1 Appearance.....	2
1.1.1 Outline diagram.....	2
1.1.2 Power terminal and external input/output terminal.....	2
1.2 Sampling system diagram	3
1.3 Name of each part and descriptions	4
1.4 Operation panel and display	5
1.4.1 Names of parts on the operation panel and descriptions.....	5
1.4.2 Outline of display screen.....	6
2. BEFORE USE	8
2.1 Installation.....	8
2.2 Mounting method	9
2.2.1 Standard panel mounting.....	9
2.2.2 Panel auxiliary plate (Screw fixing type) option.....	10
2.2.3 Panel auxiliary plate (Simple type) option.....	11
2.3 Piping method.....	12
2.3.1 Caution on piping.....	12
2.3.2 Piping	12
2.3.3 Sampling	13
2.4 Wiring.....	14
2.4.1 Power supply.....	14
2.4.2 External input/output signal connection.....	15
3. OPERATION.....	17
3.1 Warm-up operation.....	17
3.2 Preparation for measurement.....	18
3.2.1 Span concentration value setting.....	18
3.2.2 Adjusting flow rate	18
3.2.3 Zero/span calibration.....	18
3.3 Starting and exiting measurement	18
3.3.1 Starting measurement.....	18
3.3.2 Exiting measurement.....	18
3.3.3 Stopping operation	18

4. CALIBRATION AND MODE SELECTION	19
4.1 Zero/span calibration.....	19
4.1.1 Zero/span calibration.....	19
4.1.2 Span calibration.....	20
4.2 Menu mode.....	22
4.2.1 Switching ranges	22
4.2.2 Setting span concentration value.....	23
4.2.3 Keypad lock.....	24
4.2.4 Output hold.....	25
4.2.5 Display setting.....	27
4.2.6 Setting CP calculation value conditions.....	29
4.2.7 Maintenance mode	31
4.3 Maintenance mode	32
4.3.1 Selecting output.....	32
4.3.2 Adjusting output	35
4.3.3 Response time	36
4.3.4 Minus display	37
4.3.5 Password setting.....	38
4.3.6 Sensor input.....	39
4.3.7 Checking coefficient.....	40
4.3.8 Factory mode.....	41
5. INSPECTION AND MAINTENANCE	42
5.1 Daily inspection.....	42
5.2 Periodic inspection maintenance	42
5.3 Long term maintenance	43
5.4 Details of maintenance procedures.....	44
5.4.1 Internal composition.....	44
5.4.2 Replacing power fuse.....	44
5.4.3 Cleaning measurement cell	45
5.5 Airtight test.....	46
5.5.1 Airtight test.....	46
5.6 Adjustment in heat treatment furnace.....	48
6. TROUBLESHOOTING	50
6.1 Problem conditions and corrective action	50
6.2 Error message.....	51
7. SPECIFICATIONS.....	53
7.1 Specifications.....	53
7.2 Code symbols	56

1. OVERVIEW

The gas analyzer is capable of measuring the concentrations of CO₂, CO and CH₄ components in a heat treatment furnace. Maximum of 2 components are simultaneously measurable.

The optical system is used in non-dispersive infrared method with single light source. Since a high-sensitivity single-beam mass flow controller is adopted for the detector, long-term stability and maintainability are excellent. In addition, a microprocessor is built in and a large sized liquid crystal display is provided for easier operation, higher accuracy and more functions.

1.1 Appearance

1.1.1 Outline diagram (unit : mm)

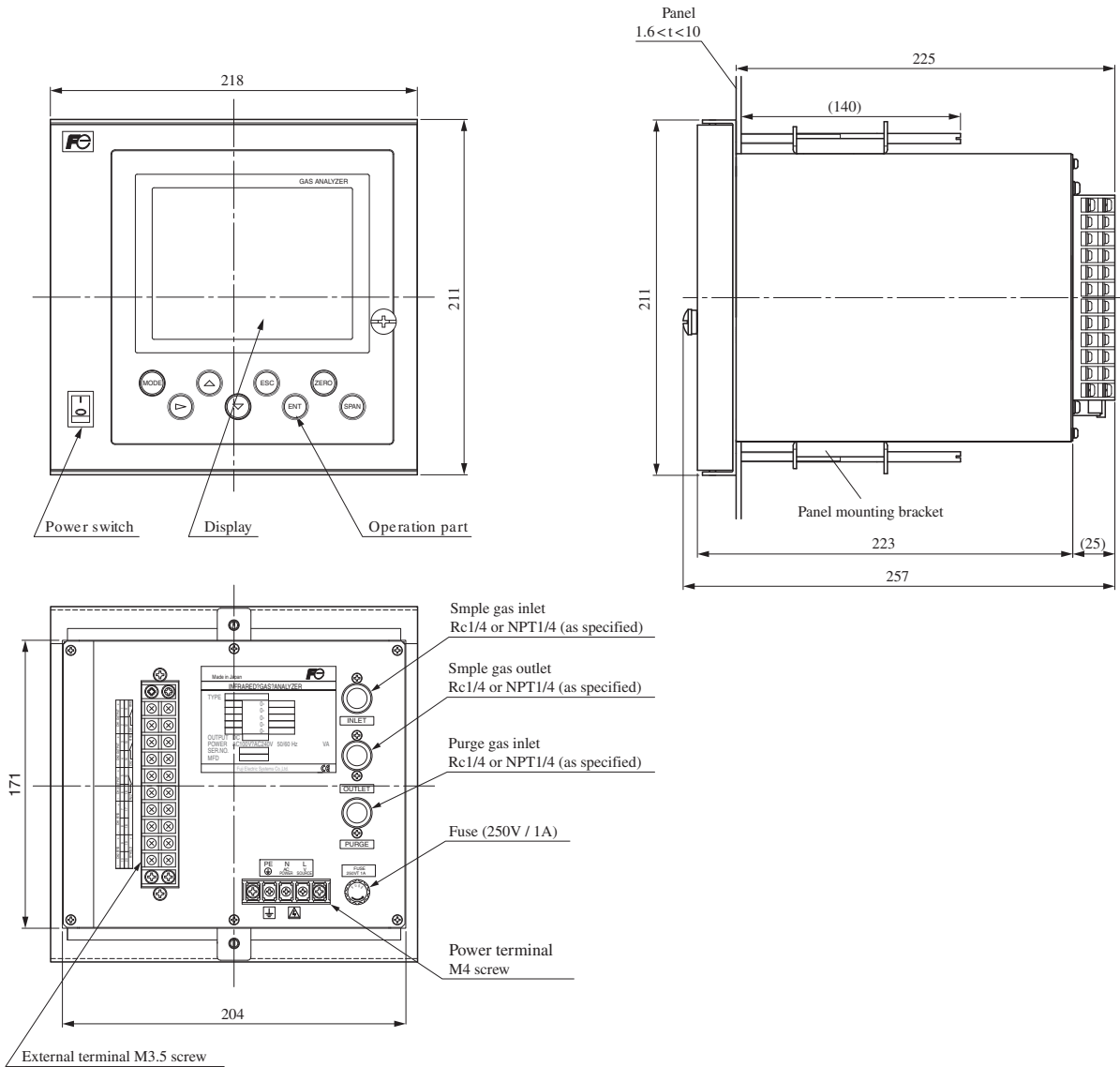

1.1.2 Power terminal and external input/output terminal

External wiring diagram

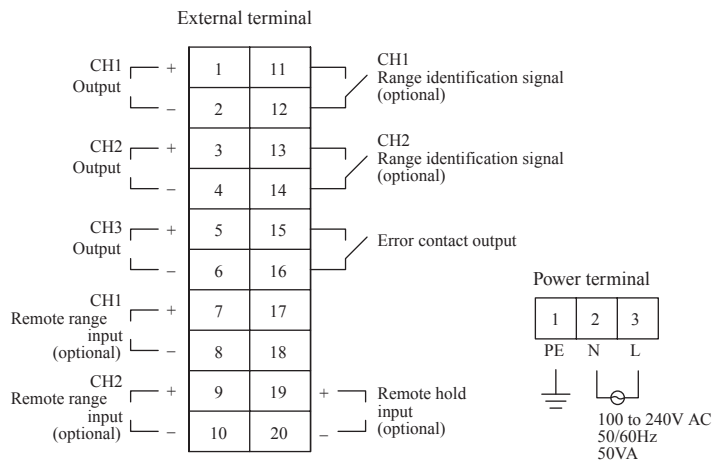

1.2 Sampling system diagram

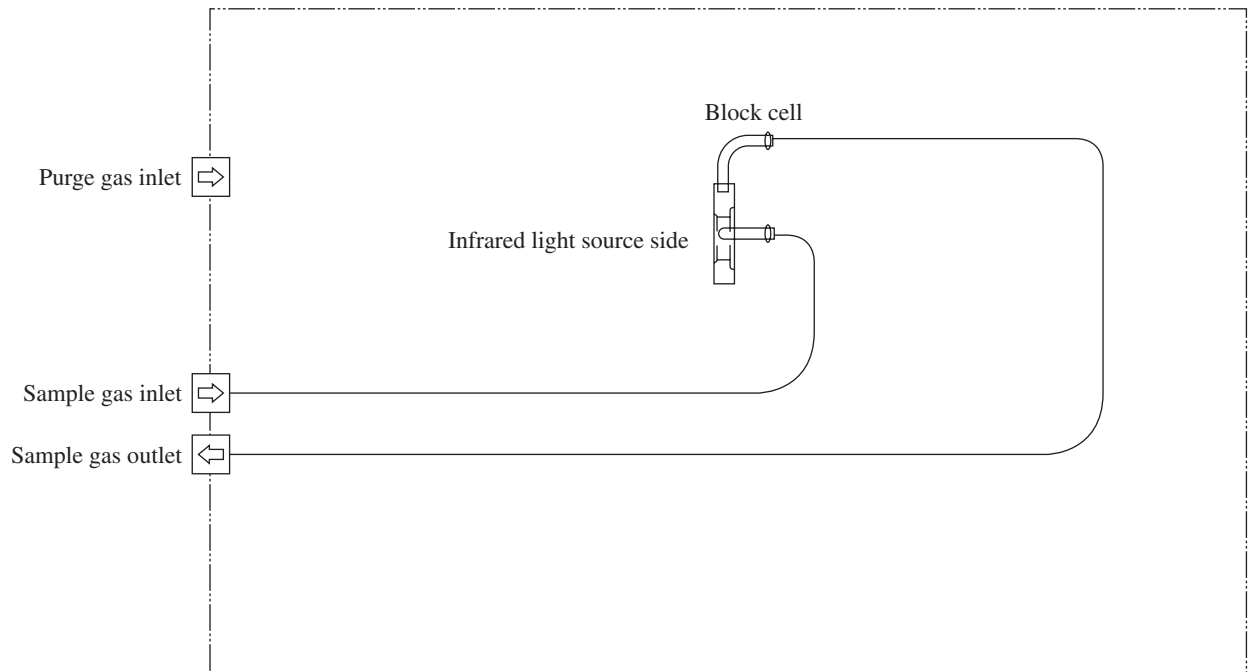

1.3 Name of each part and descriptions

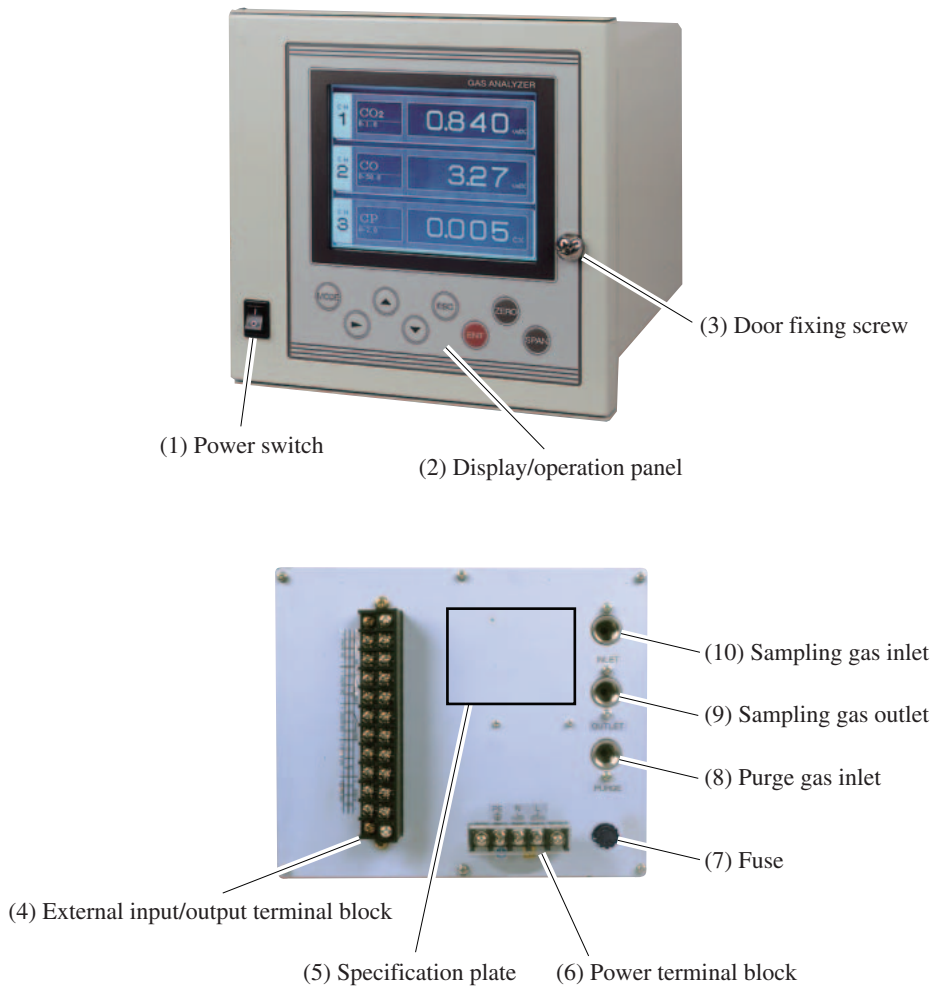

Fig. 1-1 Names of parts

Name	Description
(1) Power switch	Sets the power to ON/OFF.
(2) Display/operation panel	LCD and various setting keys.
(3) Door fixing screw	Fixes the front door.
(4) External input/output terminal block	Terminal block for various input/output signals.
(5) Specification plate	Displays serial No., components to be measured.
(6) Power terminal block	Connected to AC power cord and ground wire.
(7) Fuse	Inserts a fuse of rated capacity.
(8) Purge gas inlet	Connected to purge gas.
(9) Sampling gas outlet	Connected to exhaust line.
(10) Sampling gas inlet	Connected to sampling gas.

1.4 Operation panel and display

This section provides the names of each key for operation and display screens, and describes details of their operation.

1.4.1 Names of parts on the operation panel and descriptions

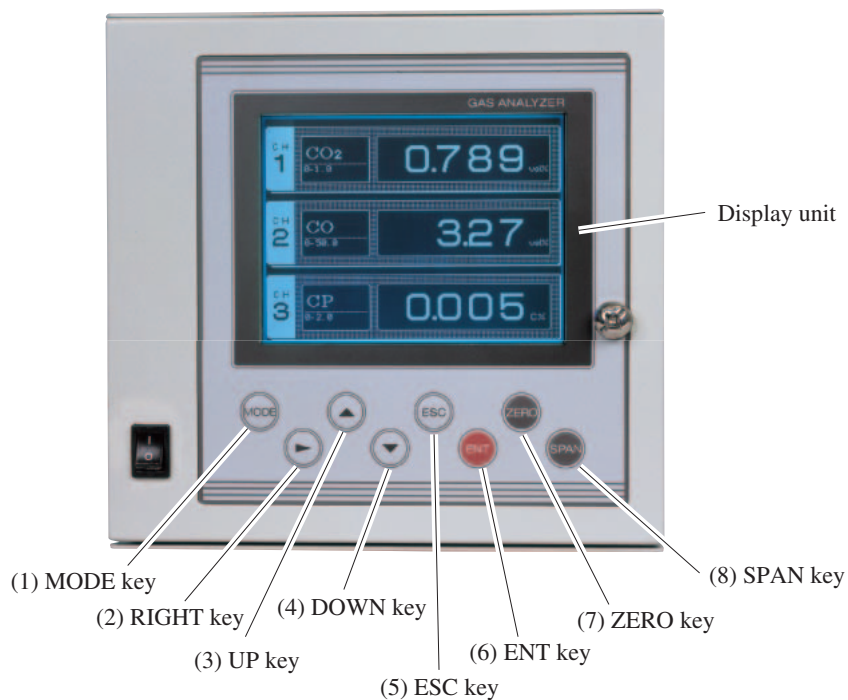

Fig. 1-2 Operation panel

Name	Description
(1) MODE key	Used to switch measurement display and mode display.
(2) RIGHT key	Used to change the digit of the setting value.
(3) UP key	Used to change the setting value.
(5) DOWN key	
(6) ESC key	Used to return to the previous screen or exit the setting.
(7) ENT key	Used for confirmation of selected items or values, and for execution of calibration.
(8) ZERO key	Enters the ZERO calibration mode.
(9) SPAN key	Enters the SPAN calibration mode.

1.4.2 Outline of display screen

(1) Measurement mode screen

After turning on the power switch, the Measurement Mode screen will appear.

The measurement screen differs depending on the number of components and optional specification.

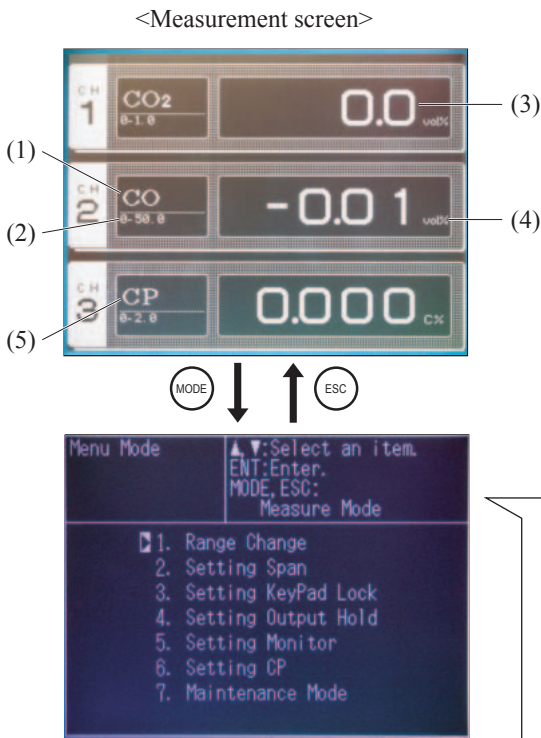

Fig. 1-3 Display screen

Name	Function
(1) Component display	Displays measurable component.
(2) Range value display	Displays measurable range values.
(3) Concentration value display	Displays concentration value.
(4) Unit display	Displays ppm and vol%.
(5) CP calculation display	Displays CP calculation value. (Option)

Menu contents

1. Range Change
Performs “range setting” of measurement target.
2. Setting Span
Performs “span calibration concentration value setting” of each component and range.
3. Setting KeyPad Lock
Performs “key operation ON/OFF setting” for erroneous input prevention.
4. Setting Output Hold
Performs “analog output hold ON/OFF setting” at zero and span calibration.
5. Setting Monitor
Performs “automatic turning-off ON/OFF setting” of backlight.
Brightness adjustment can be performed.
6. Setting CP
 - Performs “CO measured value setting” needed for calculation.
 - Performs “Furnace temperature setting”.
 Note) The selected items are displayed when CP calculation function is provided. (Option)
7. Maintenance Mode
This mode is needed when performing maintenance.

- **CP calculation value:**

The carbon potential of carburizing furnace and conversion furnace are calculated using furnace temperature (fixed input value) and CO concentration value (fixed or measured value) while referring to CO₂ measured value.

Calculation equation;
$$CP = \frac{CPS \times (PCO)^2}{K1 \times PCO_2}$$

where,

CPS ; Saturated carbon concentration (partial pressure)

$$0.0028t - 1.30 \quad (800 \leq t < 850 \text{ } ^\circ\text{C})$$

$$0.0030t - 1.47 \quad (850 \leq t < 950 \text{ } ^\circ\text{C})$$

$$0.0034t - 1.85 \quad (950 \leq t < 1000 \text{ } ^\circ\text{C})$$

t ; Furnace temperature

PCO ; CO concentration value (partial pressure)

PCO₂ ; CO₂ concentration value (partial pressure)

K1 ; Constant $K1 = 10^{(9.06 - 15966/T)}$

T ; Rankine temperature $(t \times 9/5 + 32 + 460)$

2. BEFORE USE

DANGER

This unit is not explosion-proof type. Do not use it in a place with explosive gases to prevent explosion, fire or other serious accidents.

CAUTION

- For installation, observe the rule on it given in the instruction manual and select a place where the weight of gas analyzer can be endured. A poor installation may cause accidental tip over, falling, injury, etc.
- Before transport, fix the door so that it will not open. Transporting in unstable conditions may cause injury.
- During installation work, care should be taken to keep the unit free from entry of cable chips or other foreign objects. Otherwise, it may cause fire, failure or malfunction.

2.1 Installation

To install the analyzer for optimum performance, select a location that meets the following conditions.

- (1) Use this instrument indoors.
- (2) Avoid a place where receives heavy vibration.
- (3) Select a place where atmospheric air is clean.
- (4) Power supply : Rated voltage ; 100V AC to 240V AC
Available voltage ; 85V AC to 264V AC
Rated frequency ; 50Hz/60Hz
Max. rated power ; 50VA
- (5) Power supply terminal screw : M4
- (6) Operating conditions : Ambient temperature ; -5 to 45°C
Ambient humidity ; 95% RH or less

CAUTION

- This analyzer converts 8.3Hz sensor signal to concentration value.
For this reason, output deviation may result at an area where signal cycle and vibration cycle overlap.
For installing the analyzer, avoid the vibration of about 8.3Hz or an integrated multiple.

2.2 Mounting method

Cut out the square holes according to the panel cut dimensions as shown below.

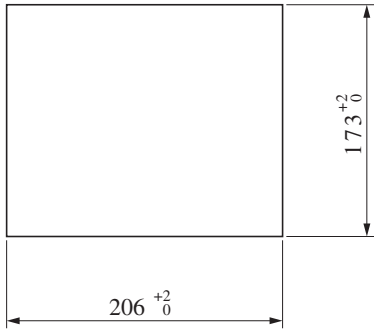

Fig. 2-1 Panel cut dimensions

2.2.1 Standard panel mounting

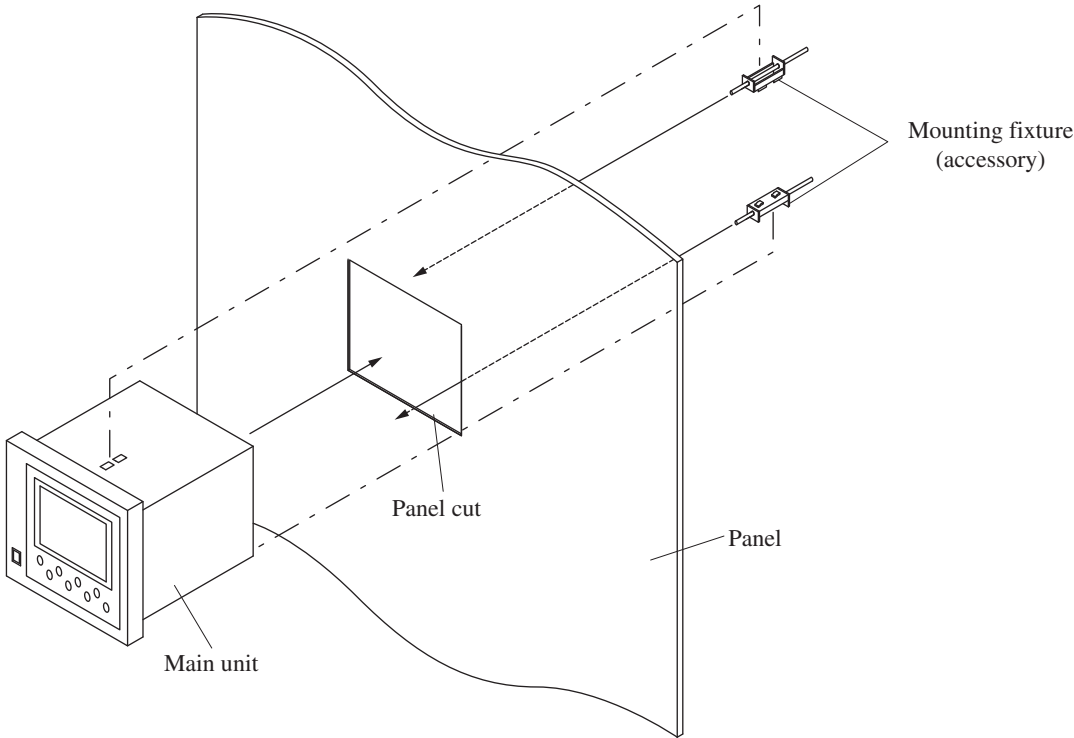

Fig. 2-2 Standard panel mounting

2.2.2 Panel auxiliary plate (Screw fixing type) option

When the existing panel hole is large, the auxiliary plate is used.
Make a cutout of 4- ϕ 4.5 in the panel.

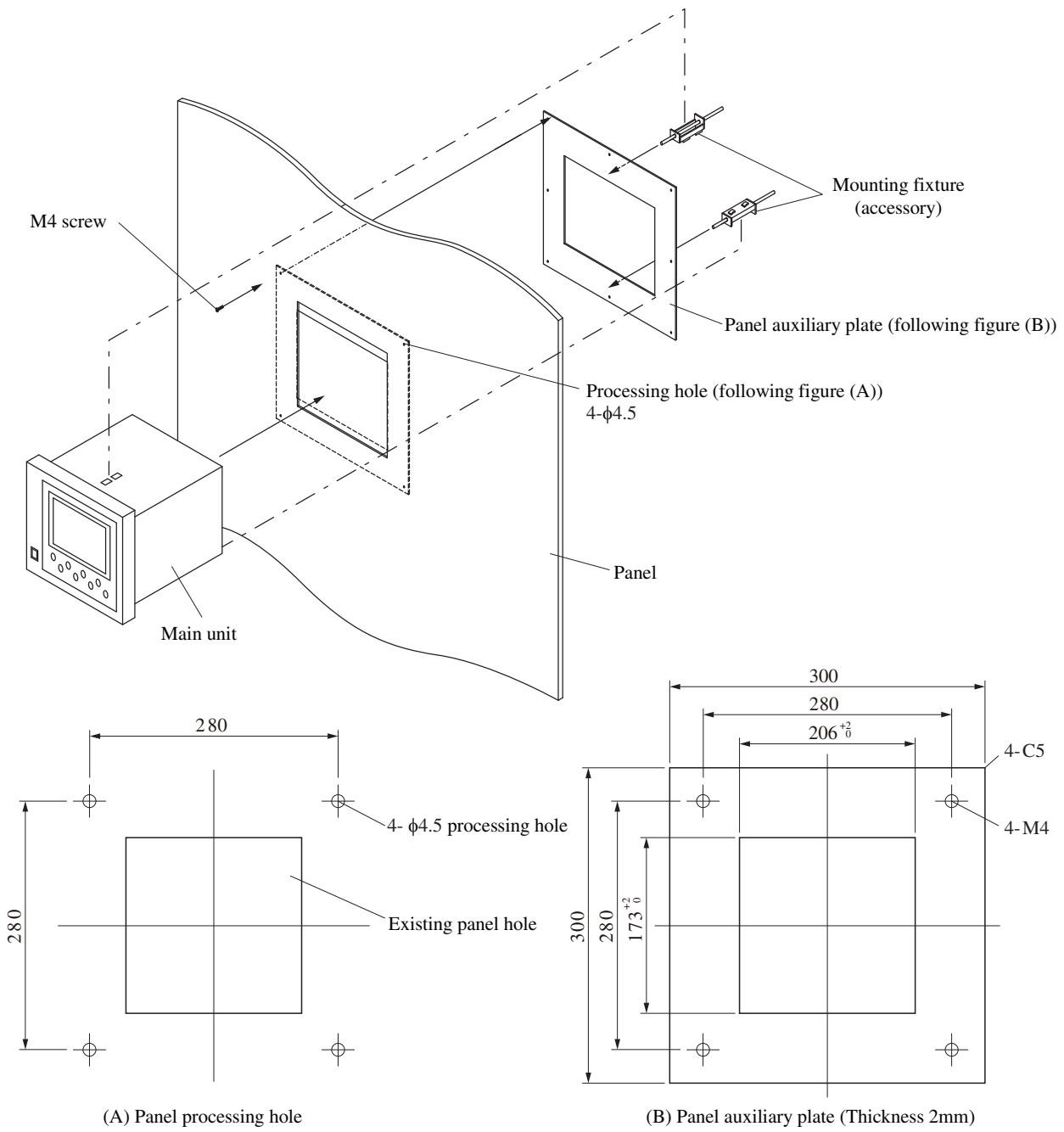

Fig. 2-3 Panel auxiliary plate mounting

2.2.3 Panel auxiliary plate (Simple type) option

When the existing panel hole is large, the auxiliary plate is used.
 Panel additional process is not necessary.

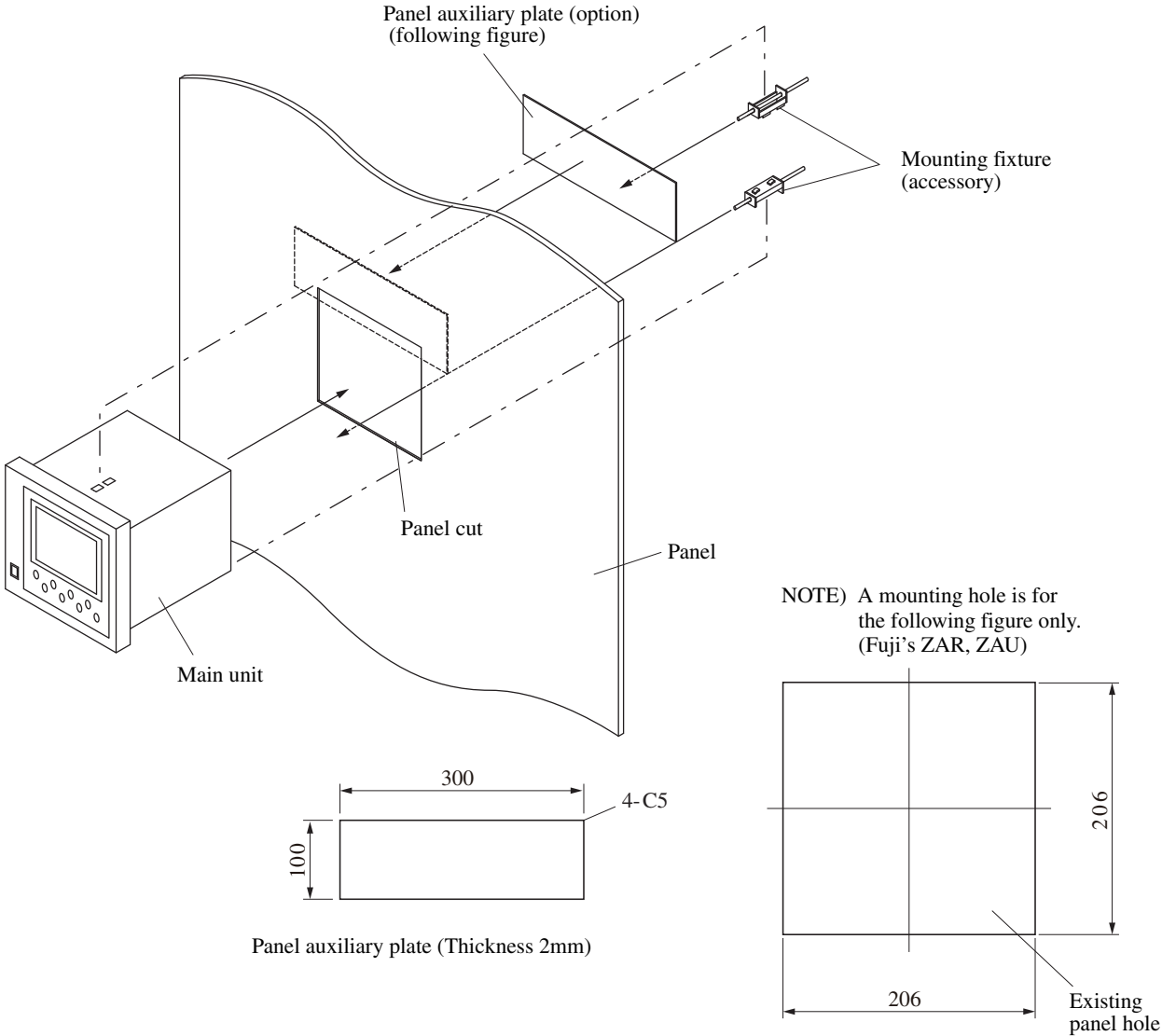

Fig. 2-4 Panel auxiliary plate mounting

2.3 Piping method

2.3.1 Caution on piping

⚠ DANGER

For piping, be sure to observe the following cautions. Wrong piping may cause gas leakage. If the leaking gas contains a toxic component, there is a risk of serious accident being induced. Also, if combustible gas is contained, there is a danger of explosion, fire or the like occurring.

- Connect pipes correctly referring to the instruction manual.
- Exhaust should be led outdoors so that it will not remain in the locker and installation room.
- Exhaust from the analyzer should be relieved in the atmospheric air in order that an unnecessary pressure will not be applied to the analyzer. Otherwise, any pipe in the analyzer may be disconnected to cause gas leakage.
- For piping, use a pipe and a pressure reducing valve to which oil and grease are not adhering. If such a material is adhering, a fire or the like accident may be caused.

Observe the following when connecting the gas pipes.

- The pipes should be connected to the gas inlet and outlet at the rear panel of the analyzer, respectively.
- Use anticorrosive tubes made of Teflon, stainless steel, polyethylene or the like for connecting the analyzer and sampling system. Avoid using rubber or soft vinyl tubes even if there is no worry about corrosion. Analyzer indication may become inaccurate due to the adsorption of gases.
- Piping connections are Rc1/4 (NPT1/4) female-threaded. Piping should be cut as short as possible for a quick response. About $\varnothing 4$ mm inner diameter is recommended.
- The pipes and joints should be clean, because dust entering the instrument may cause faulty operation.

2.3.2 Piping

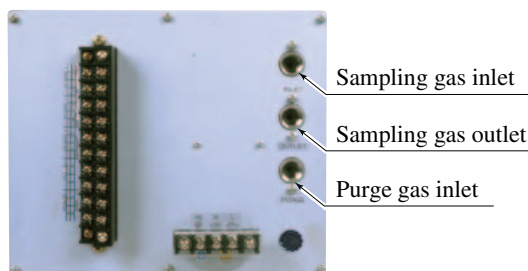

Fig. 2-5 Piping method

Sampling gas inlet : Connect the pipe so that zero/span calibration standard gas or measured gas pretreated with dehumidification is supplied properly.

Gas flow to be introduced should be constant within the range of 0.5 L/min \pm 0.2 L/min or 1.0 L/min \pm 0.5 L/min.

Sampling gas outlet : Measured gas is exhausted after measurement.

Connect the pipe so that the gas may escape through the gas outlet into the atmosphere.

Purge gas inlet : It is used for purging the inside of the total gas analyzer. When the analyzer must be purged, refer to Item 2.3.3 (4), Purging inside Analyzer.

Use dry gas N₂ or instrumentation air for purge gas. (Flow rate of 1L/min or more should be used and no dust or mist is contained).

2.3.3 Sampling

(1) Sample gas condition

1. The dust contained in sample gas should be eliminated completely with filters. For the final stage filter, use a filter that allows removing dust particles of $0.3\mu\text{m}$.
2. The dew point of sample gas must be lower than the ambient temperature for preventing formation of drain in the analyzer. If water vapor is included in the sample gas, then feed the gas through a dehumidifier to lower the dew point to around 0°C .
3. If SO_3 mist is contained in sample gas, the mist should be eliminated with a mist filter, dehumidifier, etc. The same applies if other kinds of mist are included.
4. If a large amount of highly corrosive gas such as Cl_2 , F_2 or HCl is contained in sample gas, the service life of analyzer will be shortened. So, avoid such gases.
5. The sample gas temperature should range from 0 to 40°C . Do not introduce a high temperature gas directly into the instrument.

(2) Sample gas flow rate

Flow of sampling gas should be $0.5\text{L}/\text{min} \pm 0.2\text{L}/\text{min}$ or $1.0\text{L}/\text{min} \pm 0.5\text{L}/\text{min}$.

The pressure of sampling gas should be 5kPa or less.

Provide a flowmeter to measure the flow rate.

(3) Preparation for standard gas

Prepare standard gases for zero and span calibrations.

Zero gas	N_2 gas
Span gas	Gas with a concentration of 90% or more of the full scale

Calibration gas flow should be $0.5\text{L}/\text{min} \pm 0.2\text{L}/\text{min}$ or $1.0\text{L}/\text{min} \pm 0.5\text{L}/\text{min}$.

Use the gas according to the sampling gas flow.

(4) Analyzer interior purging

Be sure to purge the inside of the instrument in the following cases.

1. A combustible gas component is contained in sample gas.
2. A corrosive gas is contained in the atmospheric air at the installation site.
3. The same gas as the sample gas component is contained in the atmospheric air at the installation.

In such cases as above, the inside of analyzer should be purged with N_2 or the air for instrumentation.

Purging flow rate should be about $1\text{L}/\text{min}$.

If dust or mist is contained in purging gas, it should be eliminated completely in advance.

(5) Pressure at sample gas outlet

Arrange so that sample gas outlet is at atmospheric pressure.

(6) Example of piping connection

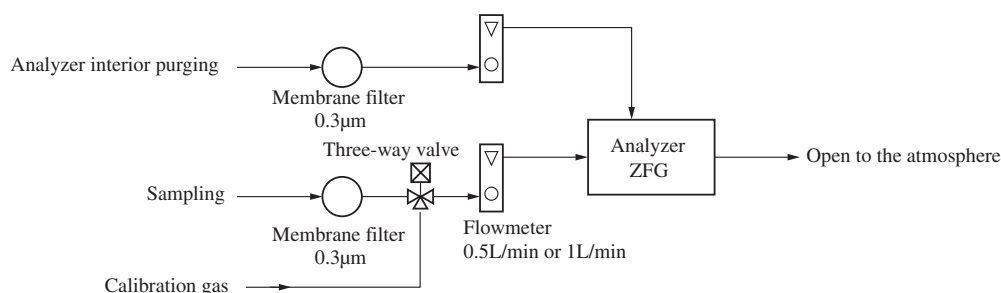

2.4 Wiring

CAUTION

- Be sure to turn off all the power before performing wiring. Otherwise electric shock may result.
- Be sure to perform Class D grounding work with the grounding lead. Otherwise, electric shock or failure may result.
- Use appropriate wiring materials conforming to the instrument's rated values. If a wire which cannot endure the rating is used, electric shock or fire may occur.
- Be sure to connect a power source of correct rating. Use of power source out of rating may cause fire.

The power terminal block and the external input/output terminal block are located on the rear face of the main unit. (Refer to Fig. 2-7.)

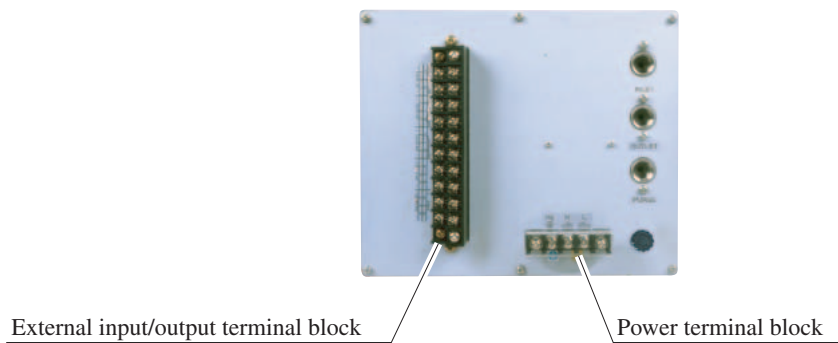

Fig. 2-7 The rear panel of main unit

2.4.1 Power supply

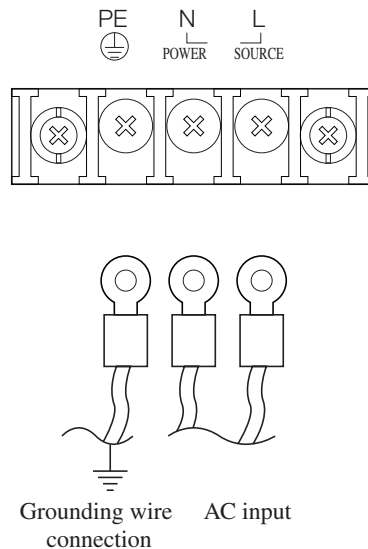
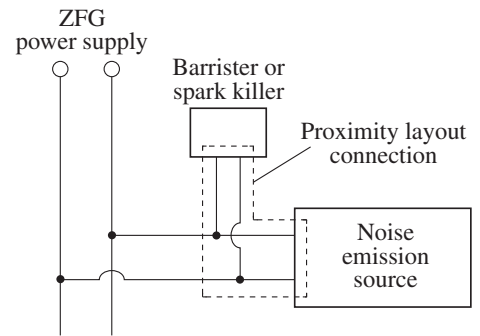

Fig. 2-8 Power supply terminal

1. Power supply terminal screw is M4. Perform M4 treatment, and connect the grounding wire to the power wiring, referring to Fig. 2-8.
2. Perform class D grounding work.
3. For power supply, use the wire which can endure the rating.

When noise emission source is near the analyzer

- Avoid installing this analyzer near an electrical apparatus which produces power source noise. (Such as high frequency furnace, electric welder, etc.) If the analyzer must be used near such equipment, a separate power line should be used for avoiding noise.
- If noise comes in from the power supply, mount a barrister or a spark killer to the noise emission source as shown by the figure at right. Note that mounting one apart from the noise emission source does not produce sufficient effect.



2.4.2 External input/output signal connection

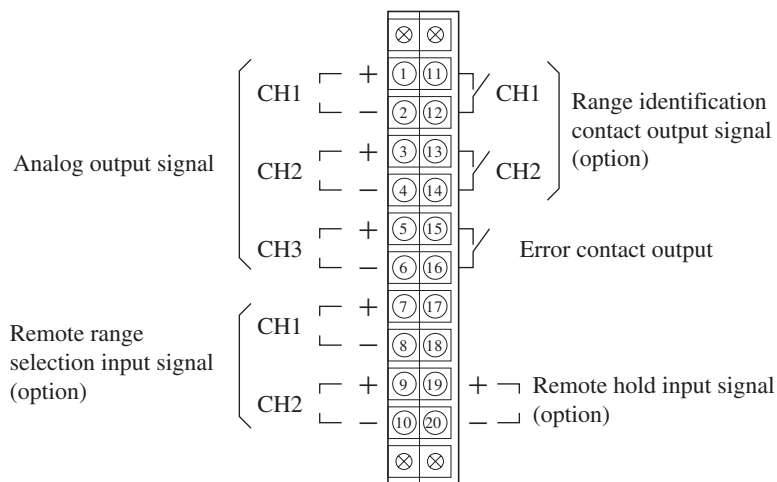

Fig. 2-9 External input/output signal terminal

(1) Analog output signal : Terminal block (1) - (2), (3) - (4), (5) - (6)

Outputs the instantaneous value of each component.
 4 to 20mA DC, 0 to 1V DC or
 0 to 10mV DC Non-insulation

Allowable load : 4 to 20mA DC, 550Ω or less
 0 to 1V DC, 0 to 100mV DC, 0 to 10mV DC, 100kΩ or more

Analog output is corresponding to the channel displayed in the measurement display.

Caution

All of analog output signals for the instrument are not isolated. It is recommended to isolate signals individually by using the insulating transformer, etc to prevent interference from unnecessary signals or to prevent external interference, especially leading the cable of more than 30 meters or to outdoor.

**(2) Remote range selection input signal : Terminal block (7) – (8), (9) – (10)
(option)**

The range is forcibly switched from the external signal.

Between (7) - (8), (9) - (10): Short-circuit ; Select the 1st range.

Open ; Select the 2nd range.

It is for a contact input at no voltage. Do not apply voltage to terminals.

**(3) Output for range identification signal : Terminal block (11) – (12), (13) – (14)
(option)**

The present range value is identified by a contact signal.

Between (11) - (12), (13) - (14): Continuity (ON) ; Select the 1st range.

Open (OFF) ; Select the 2nd range.

An output is for a relay contact output. Contact capacity is 250V AC/2A, resistive load

(4) Error contact output signal : Terminal block (15) – (16)

A contact signal is output in combination with the error display.

Between (15) - (16): Continuity (ON) ; Instrument error

Open (OFF) ; Normal

An output is for a relay contact output. Contact capacity is 250V AC/2A, resistive load

(5) Remote hold input signal: Terminal block (19) – (20)

The output is forcedly and collectively held from the external signal.

Between (19) - (20) : Short-circuit ; Execute output hold.

Open ; Output is not held.

It is for a contact input at no voltage. Do not apply voltage to terminals.

Caution

To eliminate the effect of external interference, separate the power cable from the measured value output signal cable and contact input signal cable.

3. OPERATION

3.1 Warm-up operation

- (1) Set power switch to “ON”. (“|” : ON”, “○ : OFF”).



- (2) The measurement screen is displayed.



- (3) The warm-up time is about 30 minutes after the power is turned on.

Caution on operation

The measurement can be performed during the warm-up operation, but the indication change may result.

Caution on warm-up

Note) When the power is supplied, the concentration indication may be as follows.



Exceeded the range upper limit value (range over).

Or



Exceeded the range lower limit value (range under).

This is due to fluctuation of the internal voltage. It will become stable after a few ten seconds. Also, upper/lower limit scale-out of output value or contact output ON/OFF will occur, but it is not error.

3.2 Preparation for measurement

Be sure to perform zero/span calibration of each component after the warm-up operation is completed.

3.2.1 Span concentration value setting (See “4.2.2” for setting method.)

Select “Menu Mode” → “2. Span Calibration Value”, and change calibration gas concentration value for each component range.

3.2.2 Adjusting flow rate

Connect the external flowmeter to the gas inlet side of the analyzer, and pressure the cylinder gas to 0.03MPa, and make an adjustment so that flow rate is the setting value.

3.2.3 Zero/span calibration (See “4.1” for the setting method.)

Press “Measurement screen” → “ZERO” key → “ENT” key, and perform zero calibration.
Then, press “Measurement screen” → “SPAN” key → “ENT” key, and perform span calibration.

3.3 Starting and exiting measurement

Perform measurement after zero/span calibration is completed.

3.3.1 Starting measurement

Feed the sampling gas at the specified flow rate at the measurement screen.
The sampling gas is replaced, and measurement is performed.

3.3.2 Exiting measurement

Purge the sample gas line with the zero gas.
The measured value indicates about zero point.

3.3.3 Stopping operation

Turn “OFF” the power supply switch.

4. CALIBRATION AND MODE SELECTION

4.1 Zero/span calibration

4.1.1 Zero/span calibration

Caution on calibration

The **ZERO** key is valid only in the measurement screen.
Pressing the **ZERO** key on each mode screen displays **On Setting**, and calibration cannot be performed.

Setting contents

“ON” : Executes zero calibration.
“OFF” : Does not execute zero calibration.
When “OFF” is selected for all components, zero calibration is not executed.

- (1) Press the **ZERO** key on the measurement screen.
The display is switched to the zero calibration mode.
- (2) Cursor is displayed at calibration.
Select element by the **▲** and **▼** keys, and select “ON” or “OFF” by the **▶** key.
- (3) Press the **ENT** key to move the cursor to the indication value.
- (4) Flow zero gas at the flow rate of 0.5L/min ± 0.2L/min or 1.0L/min ± 0.5L/min, and wait until the indication value becomes stable.
Use dry N₂ or dry air for zero gas.

Caution on calibration

The indication value may appear with “-” (minus), but it is not error.

- (5) After the indication has been stabilized, press the **ENT** key.
After performing zero calibration, the display automatically returns to the measurement screen.

Caution on calibration

To cancel calibration setting or calibration operation, press the **ENT** key.

Zero calibration has now been completed.

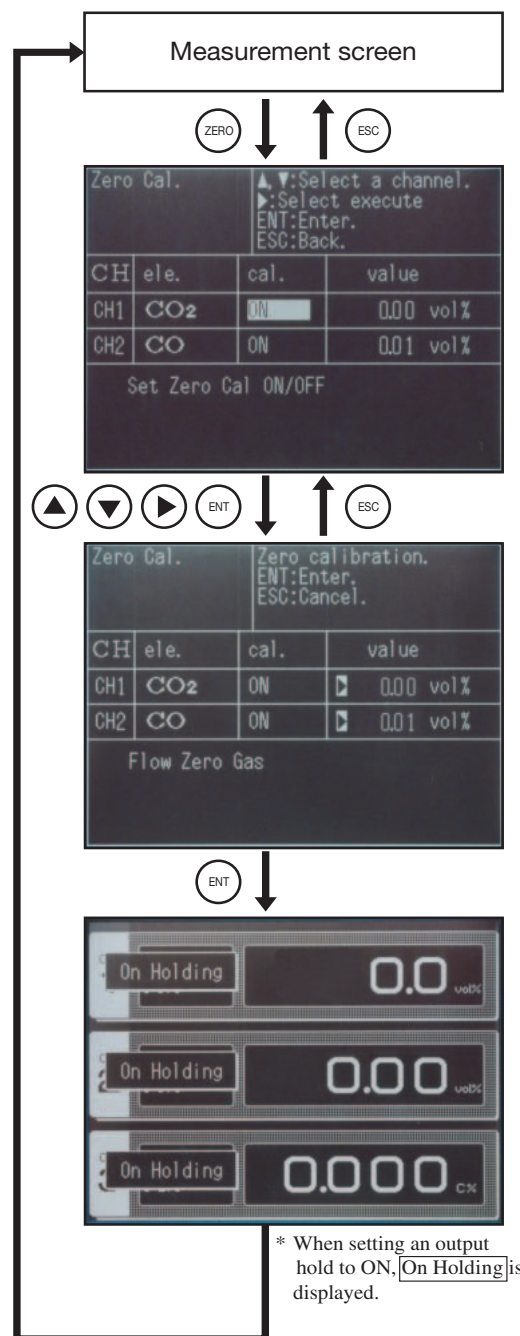

4.1.2 Span calibration

Caution on calibration

The **SPAN** key is valid only in the measurement screen.
Pressing the **SPAN** key on each mode screen displays **On Setting**, and calibration cannot be performed.

Setting contents

“both” : Carries out span calibration of 2 ranges in batch.
“each” : Carries out span calibration by range.

Operation in the case where “both” is selected.

- Press the **SPAN** key on the measurement screen.
The display is switched to the span calibration mode.
- Select calibration to “both” using the **▶** key.
- Press the **ENT** key.
Cursor moves to the range value.
Cursor flickers, and calibration is performed on the basis of range where the indication value is displayed.
- Select range by the **▲** and the **▼** keys.
- Flow span gas of reference range value, and wait until the indication value becomes stable. The flow rate of span gas should be $0.5\text{L}/\text{min} \pm 0.2\text{L}/\text{min}$ or $1.0\text{L}/\text{min} \pm 0.5\text{L}/\text{min}$.
- After the indication has been stabilized, press the **ENT** key.
After span calibration, the display automatically switches to CH2 span calibration mode screen.
Note that, if the 2nd component is not provided for specifications, it switches to the measurement screen.
- Flow the 2nd component span gas in the same manner, and perform span calibration after the indication has been stabilized.
The display switches to the measurement screen.

Caution on calibration

- To cancel calibration setting or calibration operation, press the **ENT** key.
- To jump the calibration target components, press the **MODE** key.

Span calibration has now been completed.

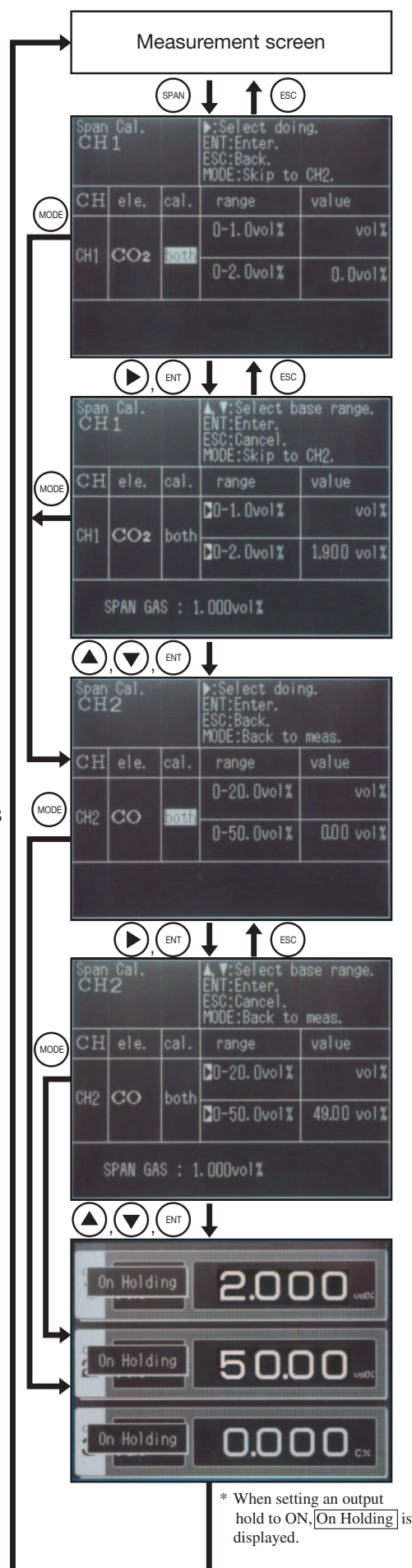

Operation in the case where “each” is selected.

- (1) Press the **SPAN** key on the measurement screen.
- (2) Select calibration to “each” using the **▶** key.
- (3) Press the **ENT** key.
Cursor moves to the range value.
Perform span calibration only for range where the cursor and the indication value are displayed.
- (4) Select range by the **▲** and the **▼** keys.
- (5) Flow span gas of the selected range, and wait until the indication value becomes stable. The flow rate of span gas should be $0.5\text{L}/\text{min} \pm 0.2\text{L}/\text{min}$ or $1.0\text{L}/\text{min} \pm 0.5\text{L}/\text{min}$.
- (6) After the indication has been stabilized, press the **ENT** key.
After span calibration, the display automatically switches to CH2 span calibration mode screen.
Note that, if the 2nd component is not provided for specifications, it switches to the measurement screen.
- (7) To perform span calibration for other ranges, return to the 1st component (CH1) using the **ESC** key, and perform calibration in the same manner.
- (8) Follow the procedure in (2) to (6) to carry out span calibration of the 2nd component.

Caution on calibration

- To cancel calibration setting or calibration operation, press the **ESC** key.
- To jump the calibration target components, press the **MODE** key.

Span calibration has now been completed.

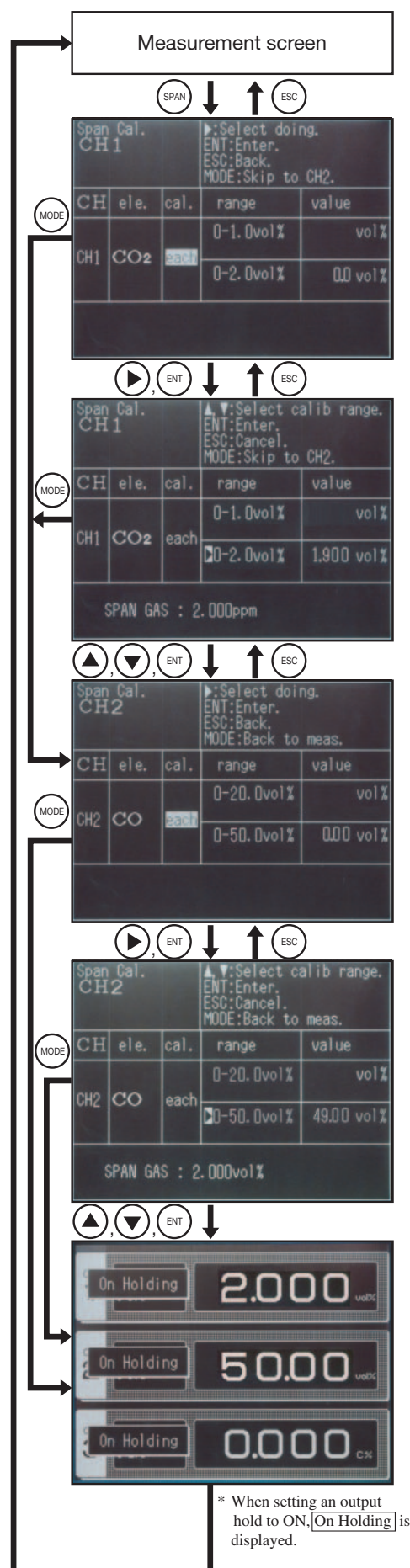

* When setting an output hold to ON, **On Holding** is displayed.

4.2 Menu mode

4.2.1 Switching ranges

The range and the display selected in this mode is output.

The CP calculation value (option) is also calculated in selection range.

Initial value

- “Minimum range”

(1) Point the cursor to “1. Range Change” using the

▲ and the ▼ keys, and press the ENT key.

The screen switches as shown at right.

Caution on setting

Remote range changeover “ON”, “OFF” selection screen is displayed only when the output option function is provided.

- Select “ON” or “OFF” by the ▲ and the ▼ keys.
- Press the ENT key.

“ON” : Range switch by the external input signal.

“OFF” : Range switch by the manual (screen) input.

(2) Select the component (CH) using the ▲ and the ▼ keys, and press the ENT key.

Cursor moves to the range value.

(3) Select range by the ► key, and press the ENT key. The range data is registered, and the previous screen appears again.

(4) Make the setting for other components (CH) in the same manner.

Caution on setting

To return to the menu mode initial screen or cancel the setting, press the ESC key.

The setting has now been completed.

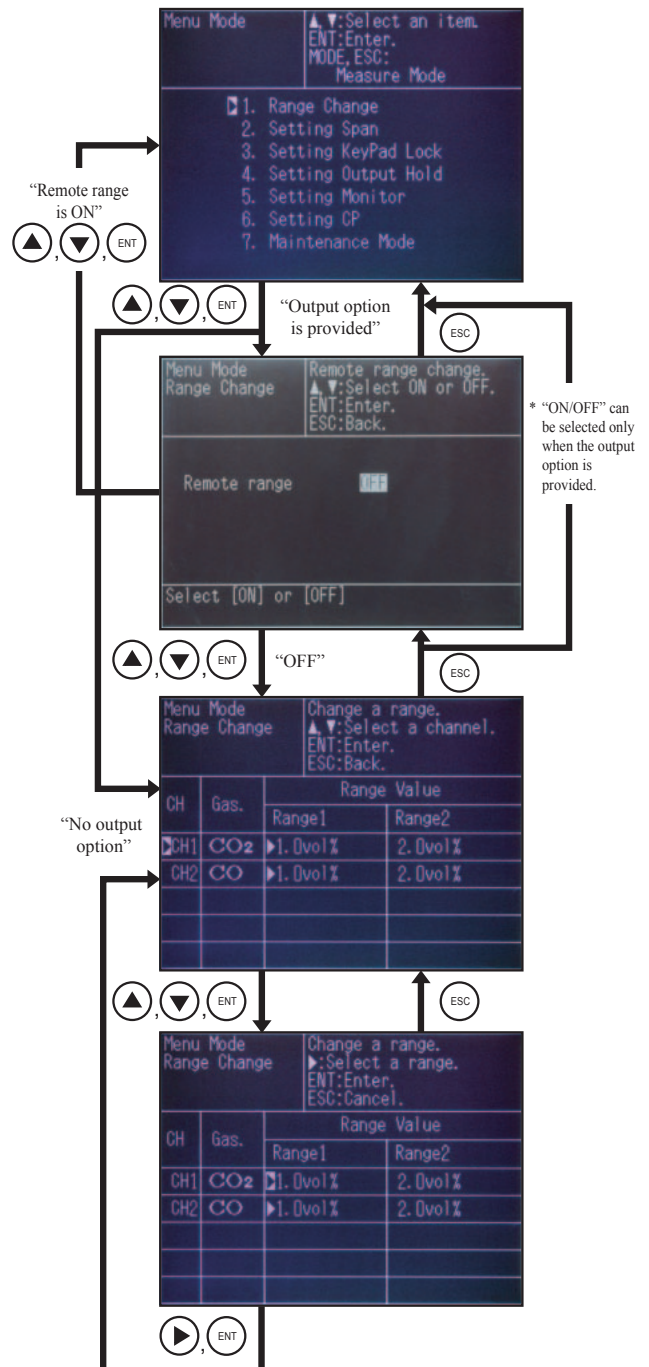

4.2.2 Setting span concentration value

Enter span gas concentration values of each component and range.

Setting range

- Minimum indication value to full scale value (FS) of each range.
- Note that, span gas concentration values for which accuracy is guaranteed is 80% to 100% of full scale.
Use the proper gas cylinder.
- Example of input range) In case of range 1.000vol %
- 0.001vol % to 1.000vol % can be entered.
 - For 0.000vol % and 1.001vol % or more, error result (previous input value is held).

Initial value

Each component and range: Internal span adjustment value or full scale value

- (1) Point the cursor to “2. Setting Span” using the and the keys, and press the key.
The screen switches as shown at right.
- (2) Select the component (CH) using the and the keys, and press the key.
Cursor moves to the span calibration value.
- (3) Select the setting range by the key.
Press the key, and cursor moves to values.
- (4) Enter the standard gas concentration value to the span calibration value using the , the , or the key.
- (5) Enter the span calibration value of other ranges and components in the same manner.

Caution on setting

To return to the menu mode initial screen or cancel the setting, press the key.

The setting has now been completed.

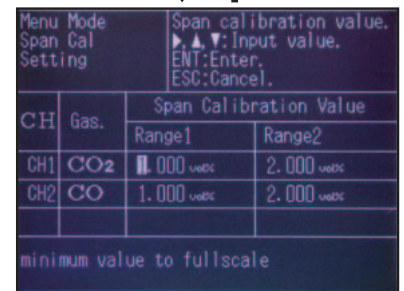
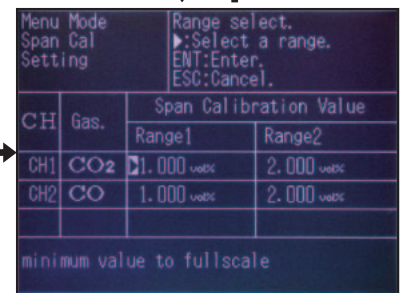
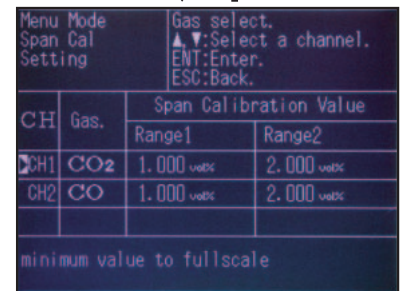
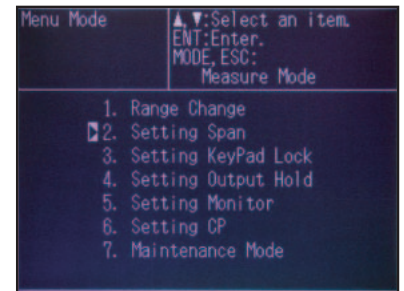

4.2.3 Keypad lock

The key lock function can be used to prevent improper operation and entry by an unauthorized person.

Setting contents

- ON : Enables keypad lock.
- OFF : Resets keypad lock.

Initial value

- OFF

Caution on setting

- The following operation can be made even when keypad lock is set to “ON”.
- 1) The setting value display in each screen can be made using the **MODE** key.
(Setting value input cannot be performed.)
 - 2) Keypad lock “OFF” (reset) setting

(1) Point the cursor to “3. Setting KeyPad Lock” using the **▲** and the **▼** keys, and press the **ENT** key. The screen switches as shown at right.

(2) Select “ON/OFF” using the **▲** and the **▼** keys.

(3) Press the **ENT** key to register the setting value. After registering, the menu mode initial screen appears again.

Caution on setting

To cancel the setting, press the **ESC** key.

The setting has now been completed.

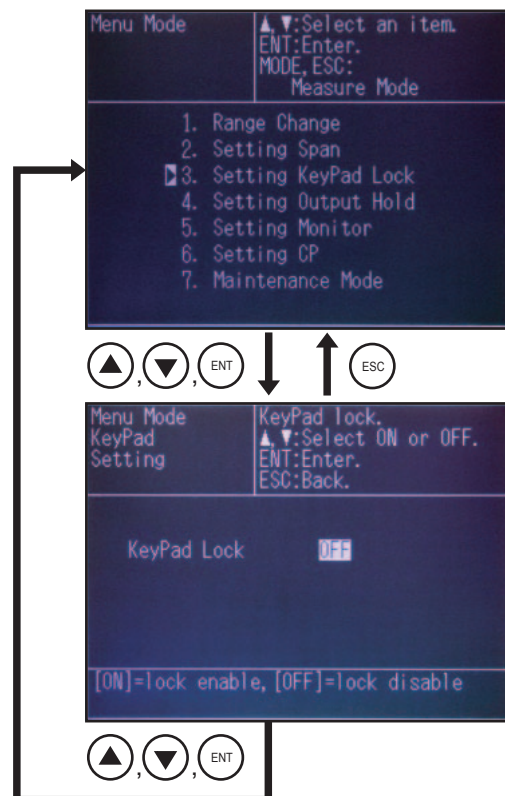

4.2.4 Output hold

Each output signal during zero calibration and span calibration, or after calibration is collectively held in the value just before the calibration. Note that Hold time can be arbitrarily set.

Setting contents

- ON : Holds output.
Replacement time: 0 sec to 999 sec
- OFF : Does not hold output.

Initial value

- OFF (Replacement time is 180 sec when it is set to ON.)

(1) Setting method

- 1) Point the cursor to “4. Setting Output Hold” using the \blacktriangle and the \blacktriangledown keys, and press the ENT key.
The screen switches as shown at right.
- 2) Select “ON/OFF” using the \blacktriangle and the \blacktriangledown keys.
 - OFF : Pressing the ENT key returns to the menu mode initial screen.
 - ON : Cursor moves to the replacement time.
- 3) Set the replacement time using the \blacktriangleright , the \blacktriangle , or the \blacktriangledown key.
Press the ENT key to register the setting value, and the menu mode initial screen appears again.

Caution on setting

To cancel the setting, press the ESC key.

The setting has now been completed.

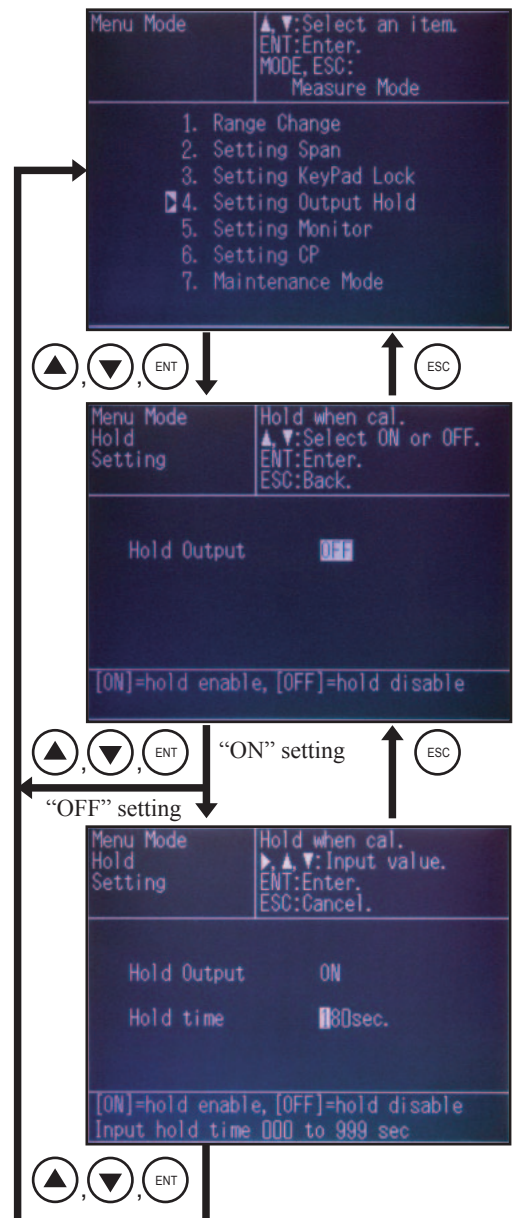

(2) Operation

Caution on operation

- Hold is valid only for output. The display does not hold.
- Remote hold function (option) is forcibly executed by the input signal regardless of this setting.

1) Zero calibration operation

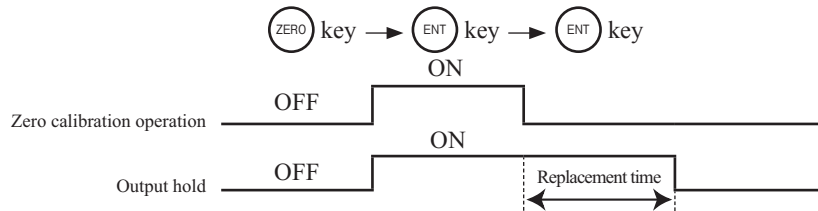

2) Span calibration operation

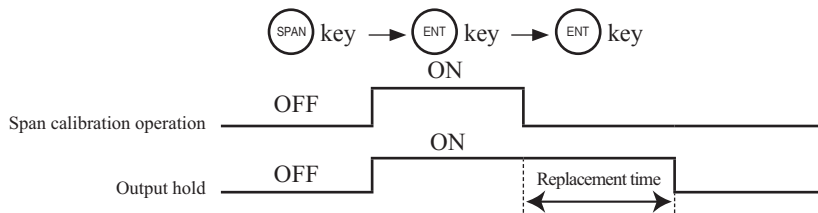

3) Remote hold operation (option)

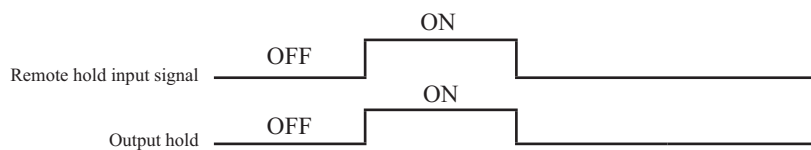

4.2.5 Display setting

Automatic ON/OFF setting and brightness adjustment of the indicator backlight can be set as follows.

Setting contents

- ON : The backlight goes off when arbitrarily set time elapses. The setting time range is [5], [10], [15], [20], [25], [30] minutes.
- OFF: The backlight does not go off.

OFF condition

- Set the setting to “ON”.
 - When the set time elapses since any key is pressed last on the measurement screen, the backlight automatically goes off.
- Note that the backlight does not go off in each setting mode.

ON condition

- When any key is pressed while the backlight stays off, it automatically comes on.

Initial value







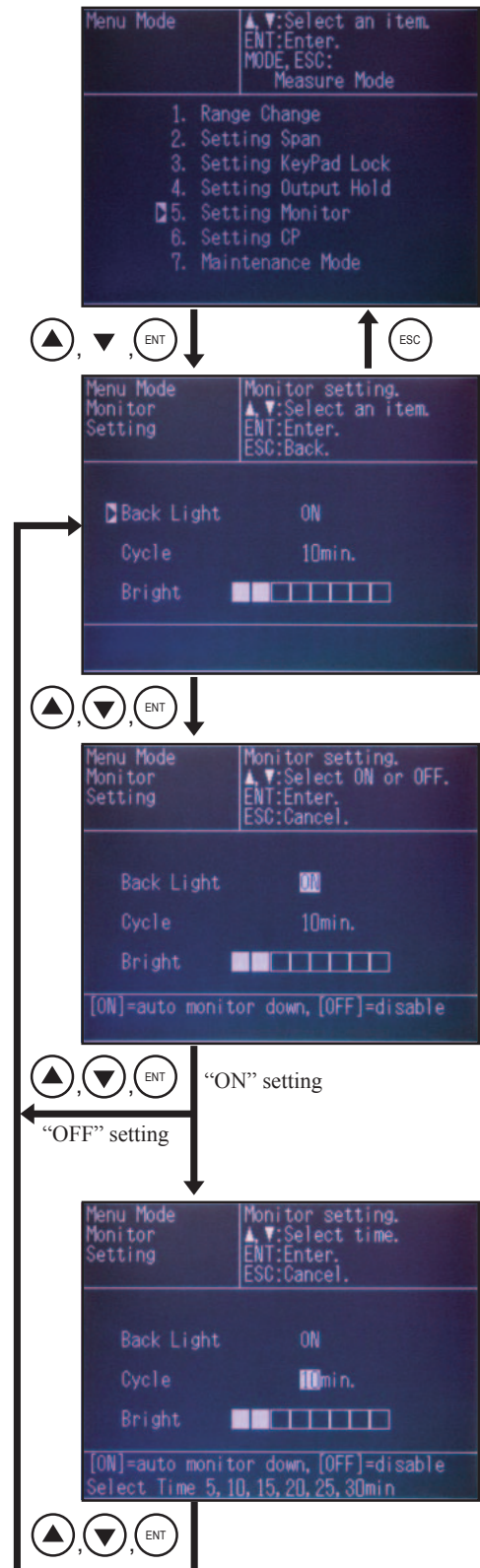

- ON (30 minutes)

(1) Turning off the backlight

- 1) Point the cursor to “5. Setting Monitor” using the and the keys, and press the key.
- 2) Select “Back Light” or “Bright” using the and the keys.
- 3) Press the key, and cursor moves to the setting value.
- 4) Select “ON/OFF” using the and the keys.
 - ON : Cursor moves to “Cycle”.
 - OFF: The previous screen appears again.
- 5) Select time using the or the keys, and press the key. The setting value is registered, and cursor moves.



(2) Brightness adjustment

- 1) Select "Bright" using the  or the  keys, and press the  key.
- 2) Cursor disappears.
Perform brightness adjustment using the  or the  keys.
 : Backlight Bright
 : Backlight Dark
- 3) Press the  key to register the setting value.

Caution on setting

To cancel the setting, press the  key.

The setting has now been completed.

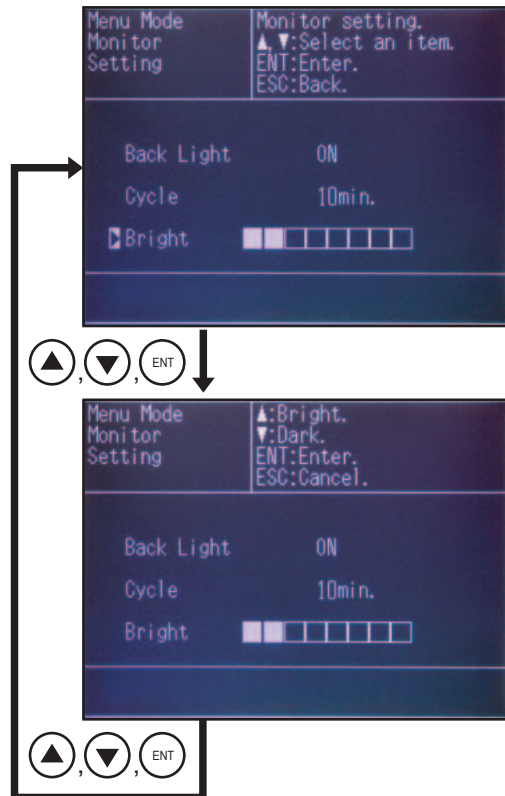

4.2.6 Setting CP calculation value conditions

Set the conditions necessary for CP calculation in this mode.

Caution on handling

This function is optional type. The mode does not display if the type is not defined.

Setting range

- CO concentration : Regular value; “10.0 to 40.0%CO”
(In steps of 0.1%)
- Furnace temperature setting : “800°C to 1000°C”
(In steps of 1°C)

Initial value

- CO concentration: “Regulated to 20.0% CO”
- Furnace temperature setting: “900°C”

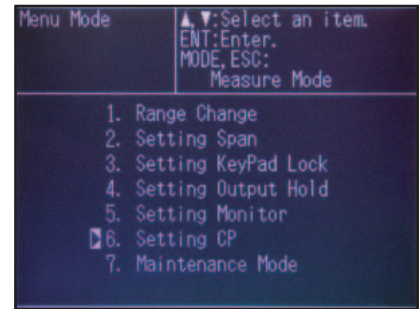

- 1) Point the cursor to “6. Setting CP” using the and the keys, and press the key.
The screen switches as shown at right.

(1) CO concentration setting

Select “Measured Value” or “Regular Value” as CO concentration required for calculation.

- 2) Point the cursor to “1. CO Concentration set” using the and the keys, and press the key.
The screen switches as shown at right.
- 3) Select measured value or regular value using the key.
- Select the measured value and press the key to return to the previous screen.
 - Select the regular value and press the key, and temporary CO concentration value is displayed.
- Select a digit using the key, and change the value using the and the keys.
Press the key to return to the previous screen.

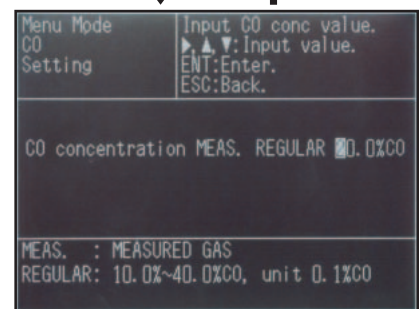
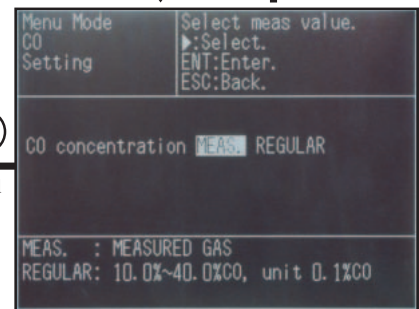
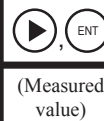
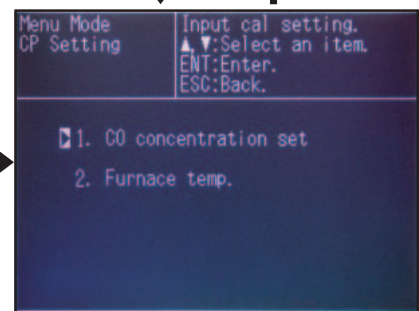



Caution on setting

If CO analyzer is not provided, “Measured Value” of CO concentration value is not displayed.





The setting has now been completed.

(2) Furnace temperature setting

Enter temporary furnace temperature value.

- 1) Point the cursor to “2. Furnace temp.” using the  and the  keys, and then press the  key.

The screen switches as shown at right.

- 2) Select a digit using the  key, and change the value using the  and the  keys. Press the  key to return to the previous screen.

The setting has now been completed.

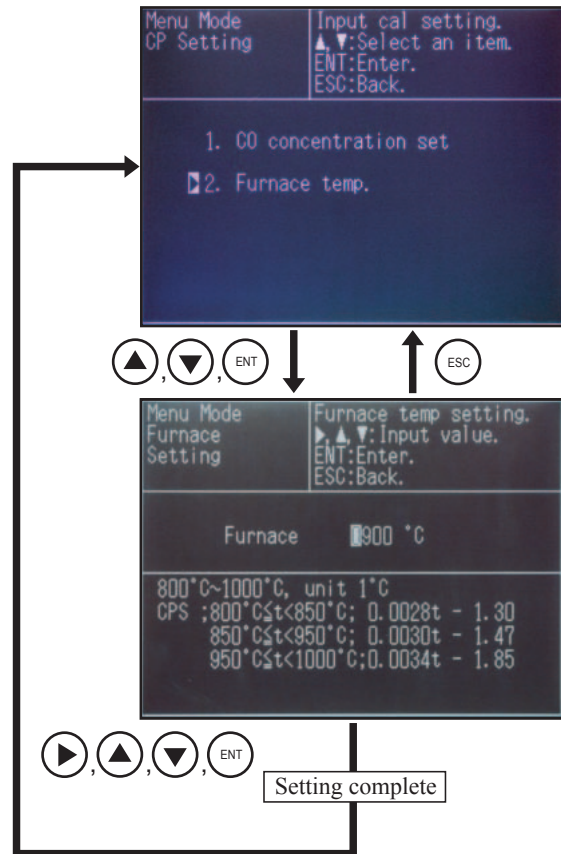



4.2.7 Maintenance mode



Enter the password to go into the maintenance mode.

Initial password

- The password is set to “0000” at the time of delivery from the factory.
- Select “Maintenance Mode” → “5. Password Set” to change the password.

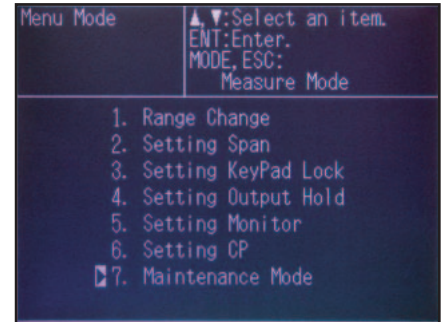
- (1) Point the cursor to “7. Maintenance Mode” using the  and the  keys, and press the  key.
The screen switches as shown at right.



- (2) Enter the password using the , the , or the  key.

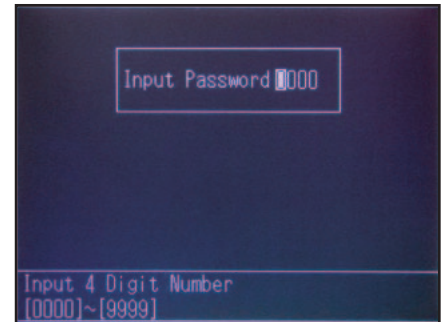

- (3) Press the  key, and the “Maintenance Mode” screen appears.
If the input value is different, the comment “Try again” is displayed.

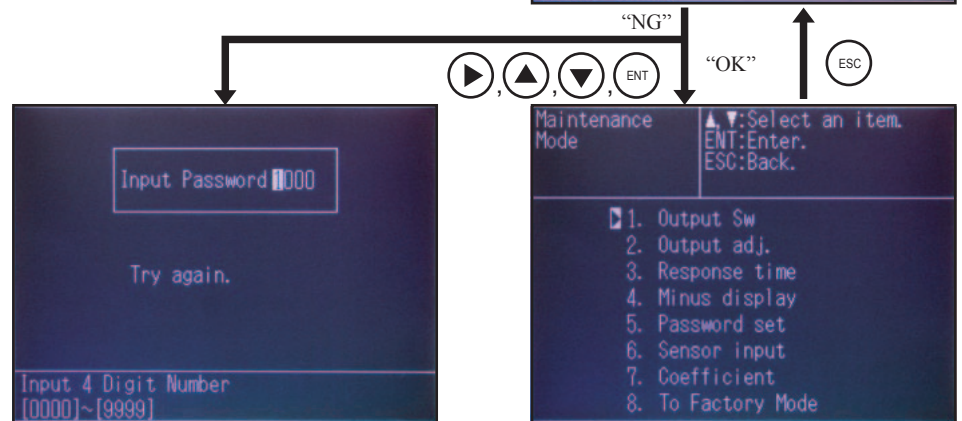

Caution on setting

To cancel the setting, press the  key.

The setting has now been completed.

4.3 Maintenance mode

Periodic inspection and failure analysis are performed in the maintenance mode.

Caution on operation

- You have to enter the password to enter into this mode. Record your password after it is changed just in case you forget it.
- This mode contains important data to maintain the accuracy of the instrument. Carry out the operation with utmost attention to prevent improper operation or malfunction.
- Switch the jumper pin after turning off the power. Otherwise electronic parts may be damaged.

4.3.1 Selecting output

Current output (4 to 20mA DC) or voltage output (0 to 1V DC, 0 to 100mV DC, 0 to 10mV DC) can be selected in this mode. To switch between current and voltage outputs, switch the jumper pin of the main printed circuit board.

Caution on setting

- When making the setting in this mode, be sure to switch the jumper pin of the main printed circuit board. Otherwise accurate output signal cannot be obtained.

Setting contents

Select “4 to 20mA DC”, “0 to 1V DC”, “0 to 100mV DC” or “0 to 10mV DC”.

Initial value

“Depends on specifications.”



Jumper switching

Output CH	4 to 20mA DC	0 to 1V DC	0 to 100mV DC	0 to 10mV DC
CH1	JP1 1-2	JP1 2-3, JP4 1-2	JP1 2-3, JP4 3-4, JP7 1-2	JP1 2-3, JP4 5-6, JP7 1-2
CH2	JP2 1-2	JP2 2-3, JP5 1-2	JP2 2-3, JP5 3-4, JP8 1-2	JP2 2-3, JP5 5-6, JP8 1-2
CH3	JP3 1-2	JP3 2-3, JP6 1-2	JP3 2-3, JP6 3-4, JP9 1-2	JP3 2-3, JP6 5-6, JP9 1-2



Note) When output is 4 to 20mA DC : Open JP4 to JP9.

When output is 0 to 1V DC : Open JP7 to JP9.

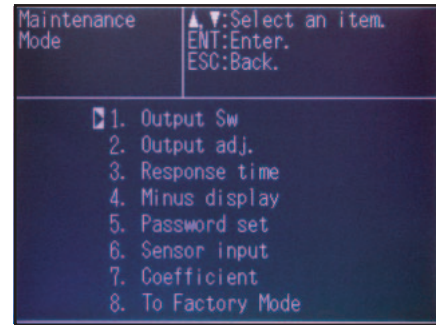

If you use 0-100 mV DC or 0-10 mV DC, be sure to contact us or the distributor where you purchased the analyzer because short-circuiting between terminals 1 and terminal 2 of JP7, JP8, and/or JP9 requires soldering work which must be done by our service engineer.

- (1) Select “1. Output Sw” using the  and the  keys, and press the  key.
The screen switches as shown at right.

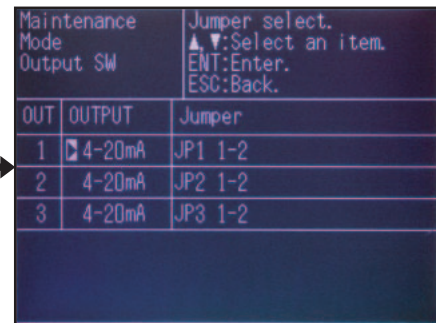

- (2) Select the output (OUT) to be changed using the  and the  keys, and press the  key.
The cursor moves.



- (3) Select the output type (4 to 20mA DC, 0 to 1V DC, 0 to 100mV DC, 0 to 10mV DC) using the  and the  keys.
Press the  key to return to the previous screen.

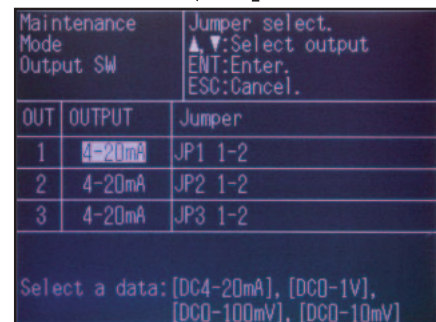

- (4) Make the setting of other output signals in the same manner.

The setting has now been completed.

4.3.2 Adjusting output

Zero value and span value of output signals can be adjusted as follows.

Preparation for the setting

- Connect an ammeter or a voltmeter to the analog output connector.



Caution on setting





- The variable setting value is for internal operation.
Check the adjusted output value with an ammeter or a voltmeter.





Tolerance of output value

- In the case of 4 to 20mA DC
Zero : 4mA \pm 0.05mA
Span : 20mA \pm 0.05mA
- In the case of 0 to 1V DC
Zero : 0V \pm 0.005V
Span : 1V \pm 0.005V
- In the case of 0 to 100mV DC
Zero : 0mV \pm 0.5mV
Span : 100mV \pm 0.5mV
- In the case of 0 to 10mV DC
Zero : 0mV \pm 0.05mV
Span : 10mV \pm 0.05mV

Adjust output as above.

- (1) Point the cursor to “2. Output adj.” using the  and the  keys, and press the  key.
The screen switches as shown at right.

- (2) Move the cursor to the output (zero, span) to be set using the  , the  , or the  key.
Press the  key, and the cursor moves to the value to be entered.

- (3) Select a digit using the  key, and change the value using the  and the  keys.
At this time, make the setting so that the ammeter or the voltmeter connected to the output signal indicates the specified value.
Press the  key, and the data is registered.
The output signal selection screen appears again.

- (4) Make the setting for other zero and span output signals in the same manner.

The setting has now been completed.

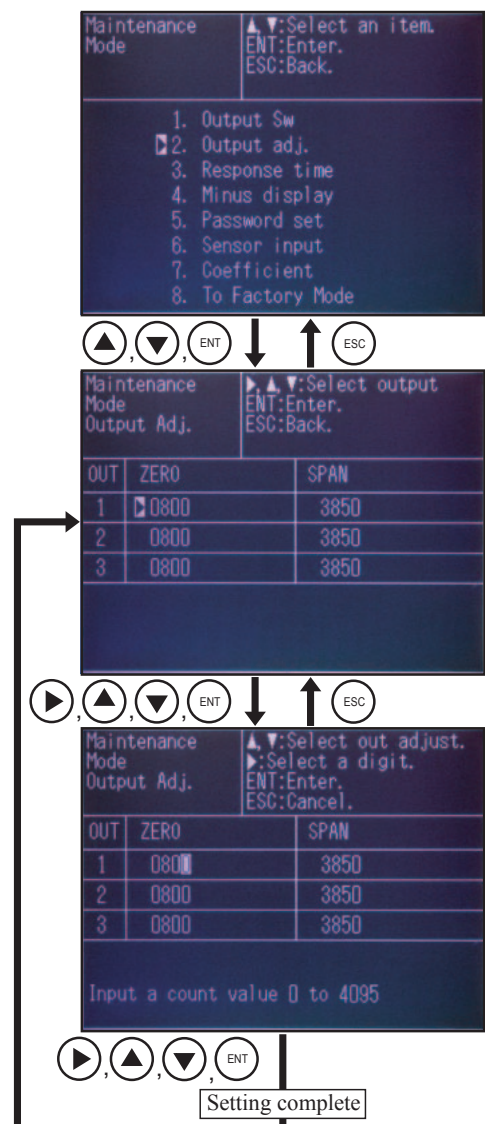

The screenshots illustrate the navigation process:

- Initial Menu:** Shows a list of options including "2. Output adj.". Navigation keys (up, down, ENT, ESC) are shown below.
- Output Adj. Selection:** Shows a table with columns for "OUT", "ZERO", and "SPAN". The cursor is on "ZERO" for output 1. Navigation keys are shown below.
- Digit Entry:** Shows the same table with the cursor on the first digit of "0800" in the ZERO column. A message at the bottom says "Input a count value 0 to 4095". Navigation keys are shown below.

A box labeled "Setting complete" is shown at the bottom right of the final screenshot.

4.3.3 Response time

Response time by internal operation (moving average) can be set as follows.

Caution on use

- The set time is for guidelines.
- The response time set here does not include gas feed and gas change time.
- In general, the longer the response speed, the slower the response time and less the fluctuation of reading.

Setting range

“01 to 60sec”

Initial value

“03 sec”

- (1) Point the cursor to “3. Response time” using the

▲ and the ▼ keys, and press the ENT key.

The screen switches as shown at right.

- (2) Move the cursor to the component to be set using the ▲ and the ▼ keys.

Press the ENT key, and the cursor moves to the value to be entered.

- (3) Select a digit using the ► key, and change the value using the ▲ and the ▼ keys.

Press the ENT key, and the data is registered.

The previous screen appears again.

The setting has now been completed.

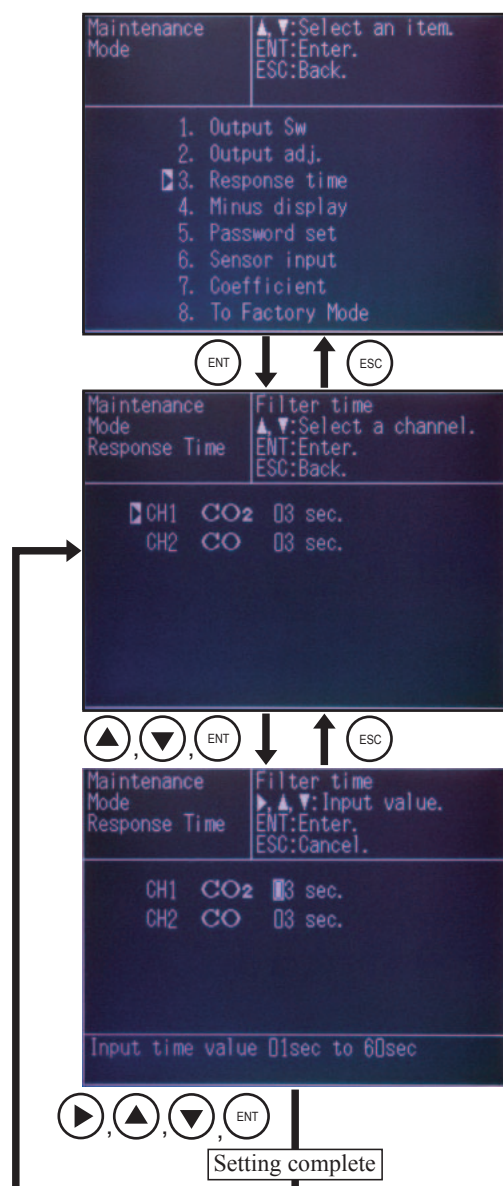

4.3.4 Minus display

The function turns minus reading into “0”.

Setting contents

- ON : Outputs minus reading. (Outputs minus value.)
 - OFF : Does not output minus reading. (Does not output minus values.)
- * The same applies to concentration value display.

Initial value

“OFF”

(1) Point the cursor to “4. Minus display” using the

▲ and the ▼ keys, and press the ENT key.

The screen switches as shown at right.

(2) Press the ENT key again, the cursor moves to the value to be entered.

(3) Change the setting value using the ▲ and the ▼ keys, and press the ENT key, and the previous screen appears again.

The setting has now been completed.

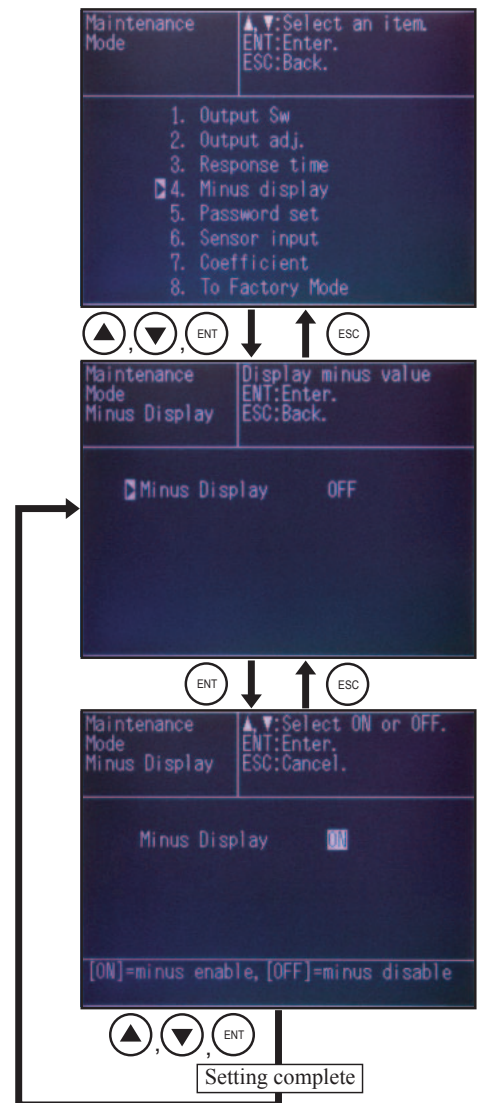

4.3.5 Password setting

The password for moving from “Menu Mode” to “Maintenance Mode” can be set as follows.

Caution on setting

- Be sure to record and store your changed password just in case you forget it.

Setting range



“0000 to 9999”

Initial value





“0000”

Common password

Enter the common password “1961” in case you forget the setting value.

- (1) Point the cursor to “5. Password set” using the  and the  keys, and press the  key. The screen switches as shown at right.

- (2) Press the  key again, the cursor moves to the value to be entered.

- (3) Select a digit using the  key, and change the value using the  and the  keys. Press the  key, and the data is registered, and the previous screen appears again.

The setting has now been completed.

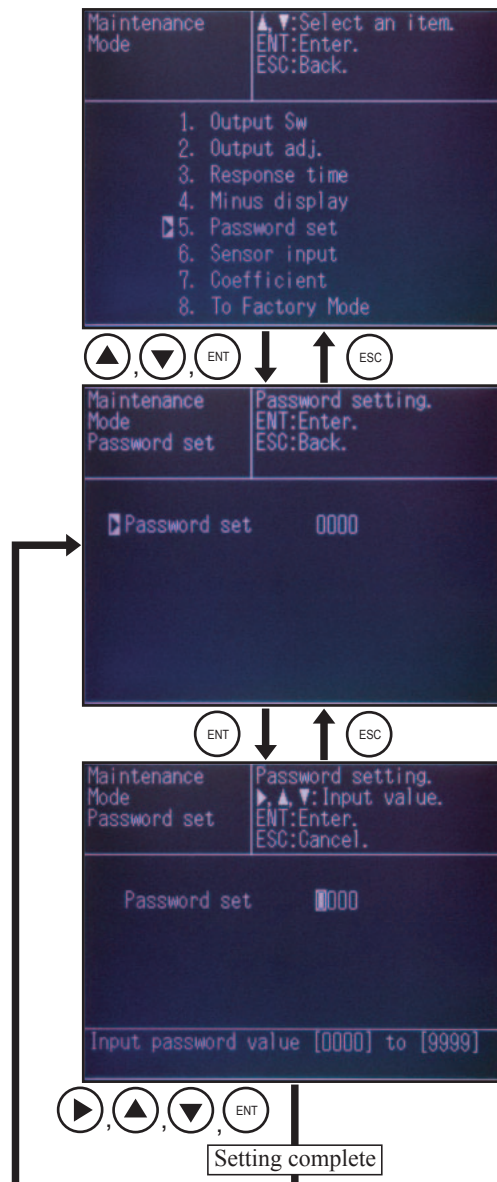

4.3.6 Sensor input

The A/D conversion values of sensor input signals can be displayed.

Description of the screen

- **Sensor** : Displays sensor components.
- **Input value** : Displays the values immediately after A/D conversion in count values.

sensor	input
CO ₂	38783
CO	40448
TEMP	18932

Caution on operation

- This mode is for displaying input values. Entry by key operation cannot be made.

- (1) Point the cursor to “6. Sensor input” using the and the keys, and press the key.
The screen switches as shown at right.



- (2) Press the key to return to the previous screen.

sensor	input
CO ₂	38783
CO	40448
TEMP	18932

4.3.7 Checking coefficient

Internal operation coefficient of “offset value” and “zero/span correction value” can be checked in this mode.

Caution on operation

- This mode is for checking the coefficient.
Entry by key operation is not allowed.

- (1) Point the cursor to “7. Coefficient” using the \blacktriangle and the \blacktriangledown keys. The screen switches as shown at right.

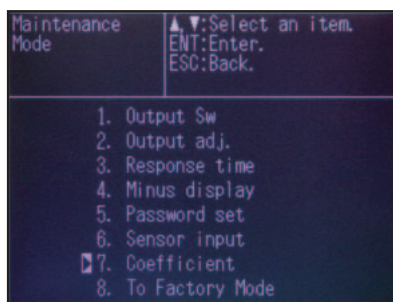

- (2) Move the cursor to the item to be checked using the \blacktriangle and the \blacktriangledown keys, and press the ENT key to enter the mode.

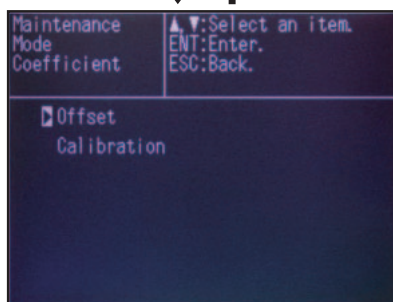

- (3) Press the ESC key to return to the previous screen.

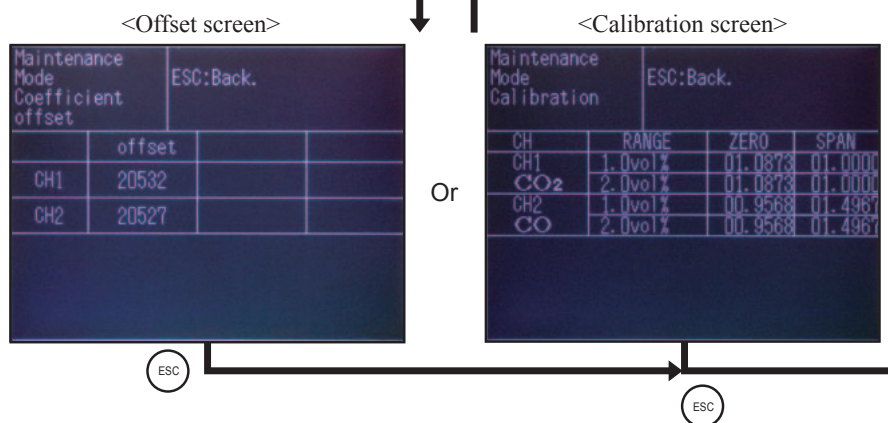

4.3.8 Factory mode

You can enter the factory mode, but you need not carry out adjustment or setting.

Description of the screen

- Changing the data in the factory mode may cause malfunction of the instrument. Do not change the data in factory mode by yourself.
- If setting change is required, contact our service representative in charge.
- See “Service Manual” for details of the factory mode.

5. INSPECTION AND MAINTENANCE

5.1 Daily inspection

(1) Zero/span calibration

- 1) Perform zero calibration. For calibration, refer to “4.1.1 Zero calibration”.
- 2) Calibrate the span following zero point calibration.
For calibration, refer to “4.1.2 Span calibration”.
- 3) Zero calibration and span calibration should be performed once a week, if required.

(2) Check of flow rate

- 1) Sampling gas flow and purge gas flow are as follows.
 - Sampling gas flow : 0.5L/min ± 0.2L/min or 1.0L/min ± 0.5L/min.
 - Purge gas flow : Approximately 1L/min
 - Calibration gas flow : 0.5L/min ± 0.2L/min or 1.0L/min ± 0.5L/min.
- 2) Maintenance and check should be carried out every day, if required.

5.2 Periodic inspection maintenance

Table 5-1 Maintenance and checking table

	Parts to be checked	Phenomena	Causes	Remedy
Portions to be checked everyday	Indication value	Reading error	(1) Dust is contained in sample cell.	(1) Clean sampling cells and check for sampling devices, especially gas filter.
			(2) When air sucked in anywhere in the sampling tube.	(2) Find out cause of leak and repair.
	Sample gas flow rate (Including flow rate of purge gas when internal purge is performed.)	Standard flow rate should be 0.5L/min. (Purging flow rate should be about 1L/min.)	_____	Adjust by needle valve of flow meter.
	Replacement of monitor filter (membrane filter)	Check for soiling	Breakage of primary filter, etc	(1) Replacement of primary filter (2) Replacement of filter paper
Portions to be checked weekly	Zero point of gas analyzer	It is deflected.	_____	Adjust.
	Span point of gas analyzer	Deviation of standard point	_____	Adjust.
	Replacement of monitor filter (membrane filter)	Regardless of any phenomena that occurred	_____	Replacement of filter paper
Portions to be checked yearly	Gas analyzer	Regardless of any phenomena that occurred	_____	Overhaul
	Gas analyzer output	After overhaul	_____	Instrument error test

5.3 Long term maintenance

Create a long-term maintenance component procurement plan based on the “Gas analyzer annual inspection plan” indicated below.

Gas analyzer annual inspection plan

The recommended replacement period of components varies depending on the installation conditions.

- 1) The recommended replacement period is a recommended standard criterion, and varies depending on the environment of the field, conditions of measuring gas and other factors.
- 2) The recommended replacement period is not the warranty period. It is provided as a preventative maintenance program baseline schedule.

- Installation conditions

Refer to Chapter 7, "Specifications".

Please consult with us regarding gas analyzer maintenance service requirements.

We may assist in providing access and support via a qualified service network.

Infrared gas analyzer annual inspection plan sheet

No.	Component name	Q'ty	Recommended replacement period (year)	Year										
				Delivered year	1st year	2nd year	3rd year	4th year	5th year	6th year	7th year	8th year	9th year	10th year
1	Galvanic fuel cell O ₂ analyzer	1 *	2			○		○		○		○		○
2	Infrared light source unit	1	5						○					○
3	O-ring for sampling cell	1	2			○		○		○		○		○
4	Detector	1 to 2 *	5						○					○
5	LCD	1	3				○			○			○	

* : Depends on models.

5.4 Details of maintenance procedures

5.4.1 Internal composition

See separate “Service Manual” for internal composition and replacement/adjustment of repair parts.

5.4.2 Replacing power fuse

Caution on replacement

- Before starting the work, be sure to turn OFF the main power.
- Prior to the following work, be sure to repair blown down fuse (short, etc), if any.

The fuse holder is located on the rear face.

- 1) Turn OFF the power switch on the front panel, and turn OFF the power supply.
- 2) Remove the cable connected to the power terminal on the rear face.
- 3) Turn the fuse holder cap counterclockwise, and pull it toward you.
- 4) Remove the fuse, and replace it with a new one. (250V AC/1A, slow-blow type)
- 5) Insert the cap into the fuse holder, turn it clockwise.
- 6) Connect the cable to the power switch on the back face, and turn ON the power supply, and then turn ON the power switch on the front face.

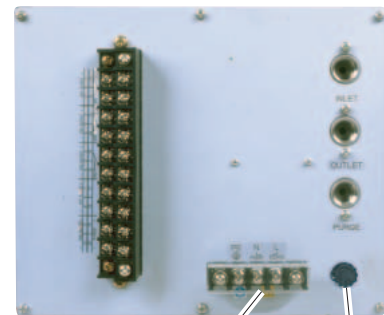

Power terminal Fuse holder

Fig. 5-1 Rear face

The work will be completed if the analyzer is normally worked.

5.4.3 Cleaning measurement cell

Caution on cleaning

For disassembly and assembly associated with cleaning measuring cell, contact our adjustment engineer before carrying out work.

If incorrect operation is made, the instrument may not operate correctly.

Entry of dust or water drops into the measurement cell may cause internal contamination, which may result in drifting.

Be sure to clean the measurement cell if contamination is found.

At the same time, check the filter in particular, to prevent the entry of dust or mist into the cell.

Four types of cells are available for measurement, namely, the block cell (length: 4mm, 8mm, 16mm, 32mm).

Cleaning the block cell (See Fig. 5-2)

- 1) Stop feeding the gas for measurement. If toxic gas is contained, purge the measurement cell fully with zero gas.
- 2) Turn off the power switch.
- 3) Remove the pipe connected to the measurement cell.
- 4) Remove the connector of the detector from the printed board. In the case of 2-component analyzer, also remove the connector of the detector for the second component (No.13 of Fig.5-2) from the printed board. Loosen the two screws fastening the detector for the second component (No.14 in Fig. 5-2), and remove the detector for the second component.
- 5) Remove the two screws (No.10 in Fig. 5-2) fastening the detector for the first component to the infrared ray light source unit. The cell can be removed together with the detector.
- 6) Loosen the two screws fastening the cell (No.6 in Fig.5-2), and remove the cell. One of the windows of the block cell is sandwiched between the detector and the block cell, but it is not fastened. Remove the cell with the detector facing up, being careful not to drop it.
- 7) When cleaning the internal surface of the cell and the infrared ray penetration window, remove large dust using a soft brush first, and then carefully wipe them with soft cloth. Never use hard cloth.

Caution

The window can be broken easily.

Handle it with care, and be careful not to wipe it strongly.

- 8) If severe contamination is found on the windows or within the cell, paste absolute ethanol on soft cloth, and wipe off the contamination with it.
- 9) If the window is found to have corroded, attach chrome oxide powder to soft cloth, and wipe the window with it if the corrosion is not so severe. If corrosion has progressed significantly, replace the window.
- 10) Reverse the procedure in 3) to 6) to assemble the cell.

Caution

Place the O-ring between the window holder and the cell. Be careful not to place it in a wrong place. In the case of 2-component analyzer, mount the detector for the second component lastly, being careful not to create a gap between the detector and that for the first component.

Insert the output cord connectors of the detector into the printed board, paying attention not to reverse the positions for the first and the second components. Insert the connector for the first component to CN11, and that for the second component to CN1.

(Upper part)

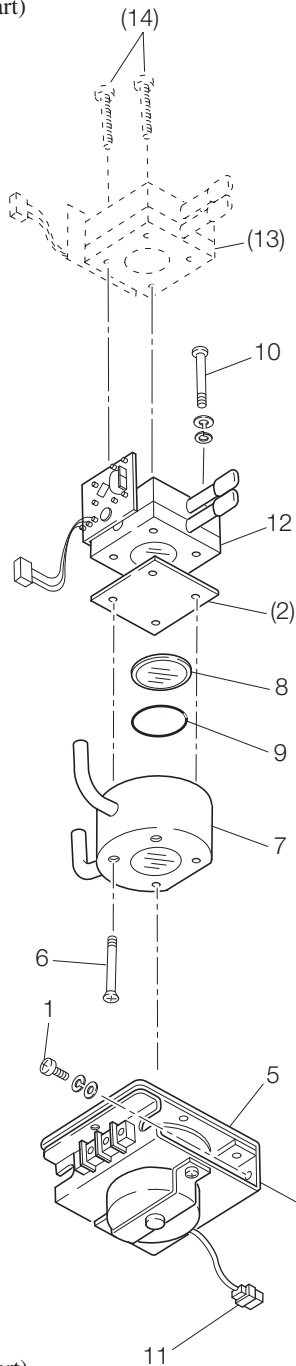

(Lower part)

No.	Name
1	Screw (for fastening light source unit)
(2)	Filter
3	Countersunk M4 screw (for fastening base board)
4	Base board (detector heat sink)
5	Infrared ray light source unit
6	Screw (for fastening block cell)
7	Block cell
8	Window
9	O-ring
10	Screw (for fastening detector)
11	Connector for chopper motor
12	Detector
(13)	Detector: For 2-component analyzer
(14)	Screw: For mounting 2-component detector

Fig. 5-2 Composition of measurement unit (block cell)

5.5 Airtight test

Be sure to carry out an airtight test after cleaning the measuring cell.
Perform an airtight test following the procedure shown below.
Set the power switch to OFF.

5.5.1 Airtight test

- 1) Close the sample gas outlet (OUTLET).
- 2) Connect standard gas cylinder (N₂ or Air cylinder) provided with pressure controller to the sample gas inlet.
- 3) Open the valve for the standard gas, and adjust the pressure on the low-pressure side to 30kPa using the handle for pressure regulation of the pressure regulator.
- 4) Fully open the handle on the outlet side, close the master valve of the standard gas cylinder, and open the handle for pressure regulation of the pressure regulator.
- 5) Maintain the above state for one minute and check that no change is found in the reading of the pressure gauge on the low-pressure side of the pressure regulator.
- 6) Airtight test of the analyzer unit has now been completed.

If leak is found, apply soap water in small quantity to each connecting section within the case to locate the position of the leak, and take measures accordingly.

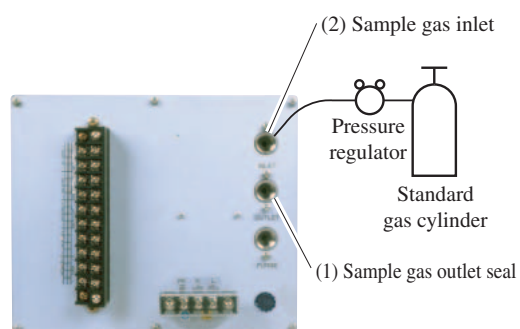

Fig. 5-3 Airtight test

Caution on performing the test

- Do not feed the standard gas at high pressure (100kPa or higher).
Otherwise the optical system may be damaged.

5.6 Adjustment in heat treatment furnace

• What is the adjustment in heat treatment furnaces?

If, in plant gases to be measured actually, a large amount of other lower-molecular-weight gases than nitrogen (N₂) such as hydrogen (H₂), or a large amount of other higher-molecular-weight gases than nitrogen (N₂) such as argon (Ar) are contained, including the measuring components, it is known that the calibration curve (output performance to gas concentration) of gas analyzers will be affected (pressure broadening).

In such a case, analyzer is adjusted with gases similar to plant gas compositions in manufacturing (adjustment by scale gas). After this adjustment, the analyzer is checked the calibration curve with N₂ balance gas (calibration curve by check gas). Graphs with these calibration curves drawn are attached to products to be supplied.

Since measurement in a heat treatment furnace has much gas of such composition, it is considering as the adjustment for heat treatment furnaces.

In order to perform exact measurement, perform the following span calibration.

Composition of the standard gas for span calibration used for each method and its method are explained using an example. For the standard gas for zero calibration, use N₂ or Air in any case so that zero point will not be affected.

<Example> Assume that a 0-1% CO₂ meter of the infrared ray gas analyzer measures CO₂ contained in plant gases.

When plant gases are composed of 0.5% CO₂, 23% CO, 30% H₂, 0.2% CH₄ and 44.3% N₂, either of the following is used as the span calibration standard gas.

	Standard gas type	Composition of standard gas	Method for span adjustment
1	Standard gas with the same composition as plant gases (scale gas)	0.9% to 1% CO ₂ , 25%CO, 30%H ₂ , remaining N ₂ *	Perform span calibration directly.
2	Check gas	0.9% to 1% CO Remaining N ₂	Perform span calibration indirectly.

* A small amount of gas like 0.2% CH₄ with little effect on span calibration may be excluded from the standard gas.

(1) Method for span calibration by standard gas with the same composition as plant gas

When using the standard gas with the same composition as plant gases given in 1, calibration can be performed without correction, as an error in calibration curve does not occur.

- 1) Set CO₂ concentration to span calibration concentration set value.
- 2) Perform span calibration by using the operation key.

(2) Method for span calibration by check gas

The method for span calibration by use of check gas (give in 2) is explained. Since span calibration has an error of calibration curve, preset a calibration indication on the calibration curve graph attached to this analyzer for indirect calibration.

1) The following calibration curve graph is attached to the test results for the product.

In graph, the calibration curve by the scale gas (that is similar to plant gas and determines scales of this analyzer) and the calibration curve by the check gas that is adjusted by the scale gas (gas of simple composition of N₂ balance gas to facilitate the analyzer check) are drawn.

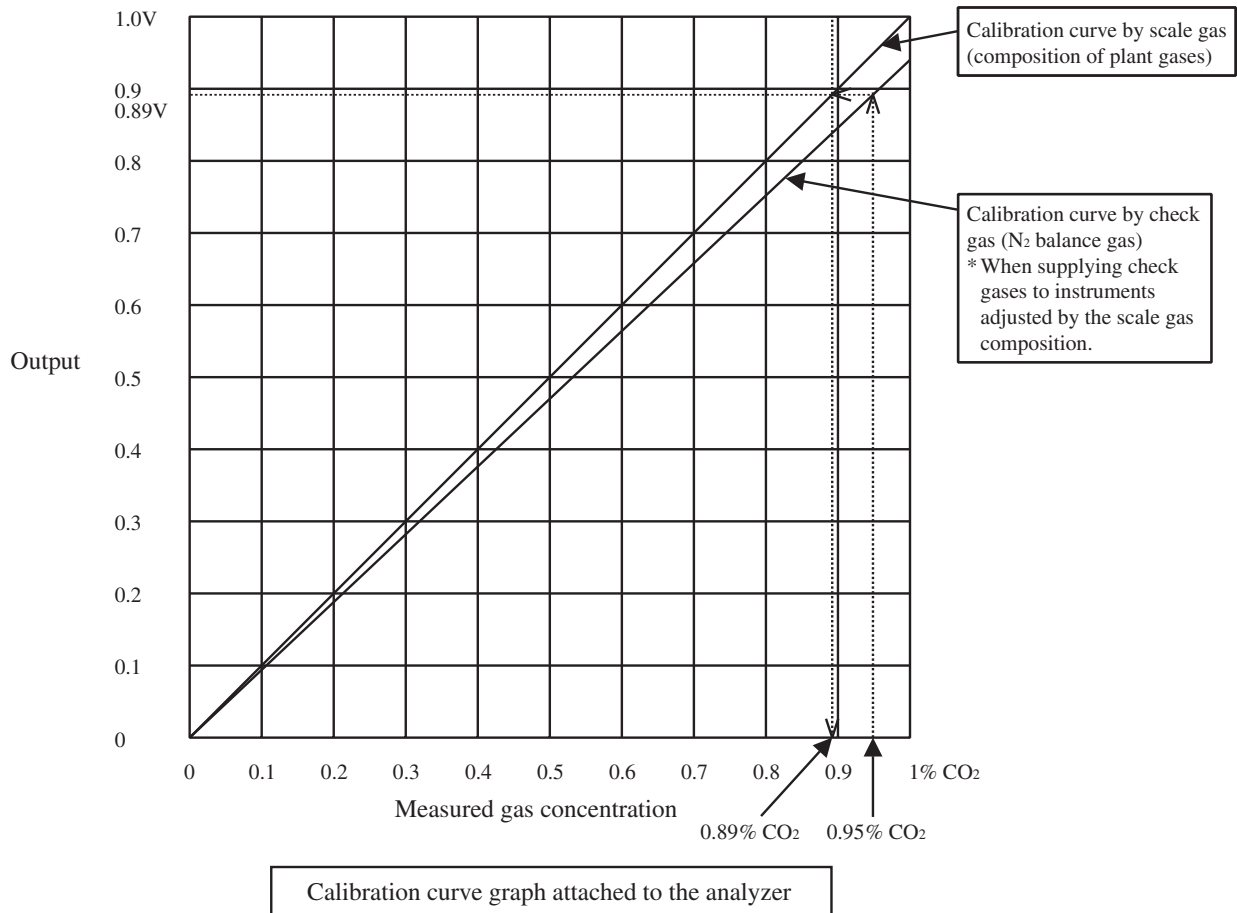

- 2) When using 0.95% CO₂ and remainder N₂ (check gas) as calibration gas, in graph, a point of 0.95% on X-axis should be stretched to upward, draw a line toward Y-axis from the cross point with the check gas calibration curve. From the cross point with calibration curve on the scale gas composition, 0.89% or equivalent values can be obtained.
- 3) Set this point (0.89%) to the span calibration concentration of the calibration concentration set value.
- 4) Supply 0.95% check gas to perform span calibration. It is calibrated to 0.89%.
Measurement suited to actual plants can be performed by this error correction of calibration curve.

6. TROUBLESHOOTING

CAUTION

In case you find it difficult to judge what happened to the instrument, avoid disassembling the instrument without consulting our sales agent or service engineers. Otherwise, it may result in electrical shock or personal injury.

6.1 Problem conditions and corrective action

Phenomena	Items	Check	Remedy
Nothing is displayed.	Automatic OFF of backlight	Press the key.	Refer to “4.2.5”.
	Life of backlight		
	Display connector faulty	Repair or replace the liquid crystal display.	Contact our service section.
	Power supply faulty	Check power supply voltage.	Check and repair wiring.
	Fuse faulty	Check and repair fuse.	Refer to “5.3.2”.
Indication differs from the anticipated one.	Gas and span calibration	Perform calibration.	Refer to “4.1”.
	Improper sealing	Check if there is gas leak anywhere.	Refer to “5.4”.
	Improper flow rate	Check the flow rate by the flowmeter.	Refer to “3.2.3”.
	Sampling devices faulty	—————	Contact our service section.
Slow response	Zero and span calibration	Perform calibration.	Refer to “4.1”.
	Gas leak	Check if there is gas leak anywhere.	Refer to “5.4”.
	Improper flow rate	Check the flow rate by the flowmeter.	Refer to “3.2.3”.

6.2 Error message

If errors occur, the following contents are displayed.

Error display	Error contents	Probable causes
Error No.1	Optical system signal faulty	<ul style="list-style-type: none"> • Infrared light source faulty • Sector motor is not properly run or is stopped. • Sector motor rotation detector circuit is faulty. • Detector is faulty. Note that 2-component detector is not detected.
Error No.3	A/D conversion signal is improper.	<ul style="list-style-type: none"> • Excessive analog input • Circuit is failure
Error No.4	Zero calibration is not within the allowable range.	<ul style="list-style-type: none"> • Zero gas is not supplied. • Zero is deflected much due to dirty cell.
Error No.5	Amount of zero calibration (indication value) is over 50% of full scale.	<ul style="list-style-type: none"> • Detector is faulty. • Analog signal is faulty.
Error No.6	Span calibration is not within the allowable range.	<ul style="list-style-type: none"> • Span gas is not supplied. • Calibrated concentration setting does not match cylinder concentration.
Error No.7	Amount of span calibration (difference between indication value and calibrated concentration) is over 50% of full scale.	<ul style="list-style-type: none"> • Zero calibration is not performed normally. • Span is deflected much due to dirty cell. • Detector sensitivity has deteriorated.

<Screen display and operation at the occurrence of error>

1) In case of Error No.1 and No.6

Measurement screen



Display of error contents

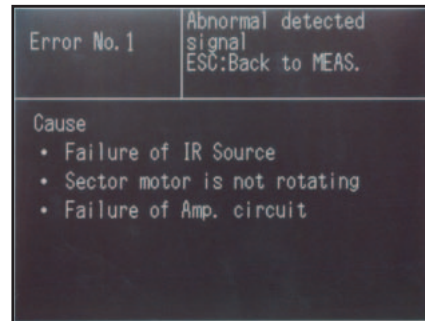

- Even if the error is canceled, the error display appears again unless the cause of the error is eliminated.
- Press the  key, and the error display disappears.

- When more than one error occurs, pressing the  key moves to another error display.

2) In case of Error No.4

Measurement screen

Zero Cal.		Zero calibration. ENT:Enter, ESC:Cancel.	
CH	ele.	cal.	value
CH1	CO ₂	Error No. 4	0.000 vol%
CH2	CO	ON	-0.001 vol%

Display of error contents

Error No. 4	Out of ZERO Cal. range ESC:Back to MEAS.
CO ₂ Calibration error	
Calibration is not successfully	
Cause	
<ul style="list-style-type: none"> • Zero gas is not flowing • Dirt in sample cell • Low sensitivity of detector 	

- Even if the error is canceled, the error display appears again unless the cause of the error is eliminated.
- Press the **ESC** key, and the error display disappears.

- When more than one error occurs, pressing the **▶** key moves to another error display.

3) In case of Error No.5 and No.7

Zero Cal.		Zero calibration. ENT:Enter, ESC:Cancel.	
CH	ele.	cal.	value
CH1	CO ₂	Error No. 5	0.000 vol%
CH2	CO	ON	-0.549 vol%
Flow Zero Gas			

Error No. 5	ZERO cal. error ENT:Enter, ESC:Back.
CO ₂ Calibration error	
Cause	
<ul style="list-style-type: none"> • Zero gas is not flowing • Dirt in sample cell • Low sensitivity of detector 	

Calibration is continued. Unless another calibration error occurs, calibration is carried out to the end, the Measurement screen returns.

CH 1	CO ₂ 8-100.0	0.0 vol%
CH 2	CO 8-50.0	-0.01 vol%
CH 3	CP 8-2.0	0.000 C%

7. SPECIFICATIONS

This product is not explosion-proof. When handling dangerous gas, adequate attention shall be paid.

7.1 Specifications

Standard Specifications

Measuring system:

Non-dispersive infrared absorption method with single light source and single beam (single beam method)

Measurable gas components and measuring range:

	Min. measuring range	Max. measuring range
CO ₂	0 to 0.5%	0 to 100vol%
CO	0 to 0.5%	0 to 100vol%
CH ₄	0 to 1%	0 to 10%

- Max. 2 components measurable
- 2 ranges selectable
- Measuring range ratio ≤ 1:5 max

Measured value indication:

Digital indication in 4 digits (LCD with back light, Automatic OFF function)

- Instantaneous value of each component
 - Result display for CP calculation (optional)
- Display language: Japanese or English selectable

Analog output signals:

4 to 20mA DC, 0 to 1V DC, 0 to 10mV DC or 0 to 100mV DC
Non-isolated output
Analog output corresponds to measured value indication in 1:1.

Allowable load resistance:

4 to 20mA DC 550Ω or less
0 to 1V DC, 0 to 100mV DC, or 0 to 10mV DC, 100kΩ or more

Contact output:

1a relay contact (250V AC/2A, resistive load) Instrument error (standard), range identification signal (optional) All relay contacts are isolated mutually from the internal circuit.

Contact input (optional):

No-voltage contact (ON/0V, OFF/5V DC, 5mA flowing at ON) Remote range changeover input, remote hold input isolated from the internal circuit with photocoupler. Contact inputs are not isolated from one another.

Power supply:

Rated voltage 100 to 240V AC
Operating voltage 85 to 264V AC
Frequency; 50Hz/60Hz
Power consumption; 50VA max.

Operation conditions:

Ambient temperature; -5 to 45°C
Ambient humidity; 95% RH or less, no condensation

Storage conditions:

Ambient temperature; -20 to 60°C
Ambient humidity; 95% RH or less, no condensation

Dimensions (H × W × D):

211 × 218 × 257 mm

Mounting dimensions:

Panel flash-mount type (vertical mounting on panel)

Weight:

About 5 kg

Finish color:

Off-white (Munsell 10Y7.5/0.5 or equivalent)

Enclosure:

Steel casing, for indoor use

Material of gas-contacting parts:

Gas inlet/outlet; SUS304, Sample cell; SUS304/neoprene rubber, Infrared-ray transmitting window; C_aF₂
Internal tubing; Toaron

Gas inlet/outlet:

Rc1/4 or NPT1/4 internal thread (as specified)

Purge gas flow rate:

1 L/min (to be purged as required)

External terminal:

Power terminal; M4 screw, Others; M3.5 screw

Performance

Repeatability:

Within ±0.5% of full scale

Linearity:

Max. ±1.0% of full scale (max. ±2.0% of full scale when range ratio is 1:4 or 1:5)

Zero drift:

Within ±2% of full scale/week

Span drift:

Within ±2% of full scale/week

Response time (for 90% FS response):

Within 10 seconds

Interference from other gas components:

Within ±2%

Warm-up time:

Approx. 30 minutes

Description of functions

Automatic OFF function (standard):

After OFF time is set, the LCD backlight automatically turns off when no key is operated. Press any key to turn on.

Output signal holding (standard):

By setting an output hold to ON, analog output signal is held in the value just before the manual calibration.

Instrument error contact output (standard):

When the main unit is abnormal, contact signal output is provided.

CP calculation (optional):

The carbon potential of carburizing furnace and conversion furnace are calculated using furnace temperature (fixed input value) and CO concentration value (fixed or measured value) while referring to CO₂ measured value.

$$\text{Formula; } CP = \frac{CPS \times (PCO)^2}{K1 \times PCO_2}$$

CPS ; Saturated carbon concentration (partial pressure)
0.0028t-1.30 (800°C ≤ t < 850°C)
0.0030t-1.47 (850°C ≤ t < 950°C)
0.0034t-1.85 (950°C ≤ t < 1000°C)

t ; Furnace temperature (°C)

PCO ; CO concentration value (partial pressure)

PCO₂; CO₂ concentration value (partial pressure)

K1 ; Constant K1 = 10 (9.06 - 15966/T)

T ; Rankine temperature (t × 9/5 + 32 + 460)

Remote output holding (optional):

Output signal is held at the latest value or setting value by short-circuiting the remote output holding input terminals. Holding is maintained while the terminals are short-circuited. Indication values will not be held.

Remote range changeover (optional):

Range is selected by the contact input signal. Changeover is effective only when remote range setting is turned on. In this case, measuring range cannot be changed manually. When the contact input terminals for each component are short-circuited, the first range is selected, and it is changed over to the second range when the terminals are open.

Range identification signal (optional):

The present measuring range is identified by a contact signal. When the contact output terminals for each component are closed, the first range is selected, and it is changed over to the second range when the terminals are open.

Standard Requirements for measuring gases**Flow rate:**

0.5L/min \pm 0.2L/min or 1L/min \pm 0.5L/min

Temperature:

0 to 40°C

Pressure:

5kPa or less (Gas outlet side should be open to the atmospheric air.)

Dust:

0.3 μ m or less

Mist:

Unallowable

Moisture:

Below a level where saturation occurs at room temperature (condensation unallowable).

Corrosive component:

HCL 1ppm or less

Standard gas for calibration:

Zero gas; Dry N₂ or dry air

Span gas; Each sample gas having concentration 90 to 100% of its measuring range (recommended).
Unusable at concentrations beyond 100%.

Installation condition

- Mount the instrument in a place that is not subject to direct sunlight, weathering nor radiation heat from high-temperature objects.
If such a place cannot be found, a roof or cover should be prepared for protection.
- Avoid a place where receives heavy vibration.
- Select a clean environment.
- Discharge the exhaust gas into atmospheric air at a safe location.
- Avoid using the analyzer in an explosion-proof area.

Standard gas sampling system

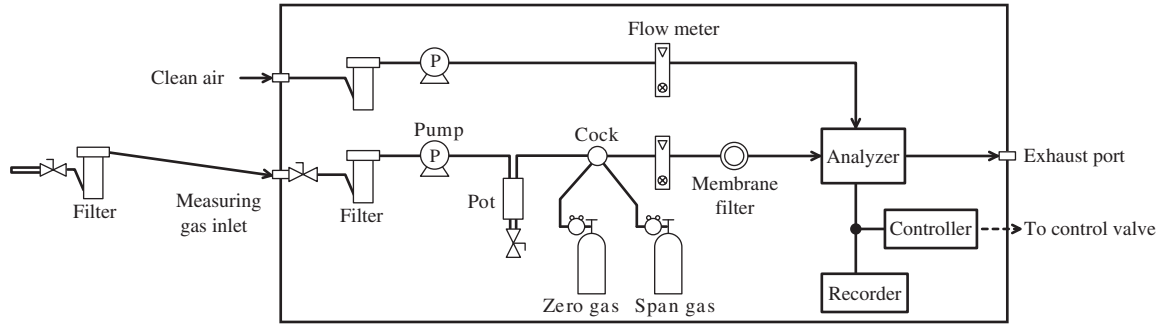

Note) This is the example of sampling which dose not contain water in the measuring gas.

Principle diagram of NDIR type measurement (For CO, CO₂, CH₄)

Quantity of infrared ray that is absorbed by the measuring cell is detected with the mass flow sensor.

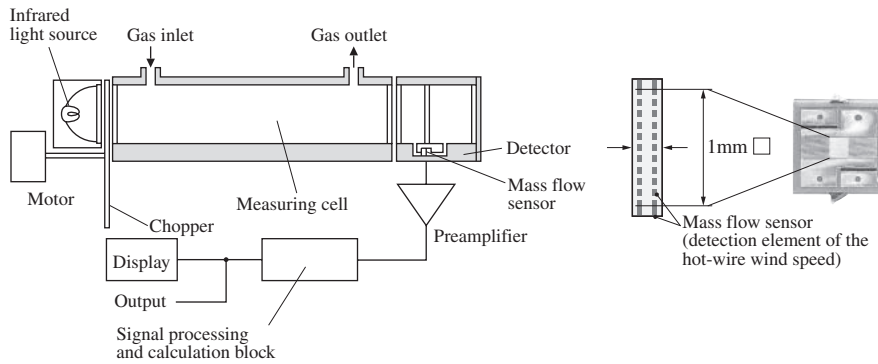

7.2 Code symbols

Digit	Specification		4	5	6	7	8	9	10	11	12	13	14	15	16	
4	Standard		F				3									
5	Measurable components	1st component CO CO ₂ CH ₄ CO ₂ CH ₄ CO ₂		B D E G H J												
		2nd component Without Without Without CO CO CH ₄														
6	Gas inlet/outlet connection	Rc1/4 NPT1/4					1 2									
7	Output signal	4 to 20mA DC 0 to 1V DC 0 to 100mV DC 0 to 10mV DC					1 2 3 4									
8	Modification No.						3									
9	1st component, 1st range (See the page 57)	0 to 0.5% 0 to 1% 0 to 2% 0 to 3% 0 to 5% 0 to 10% 0 to 20% 0 to 25% 0 to 40% 0 to 50% 0 to 70% 0 to 100% Others						H J K Q L M N V W P X R Z								
10	1st component, 2nd range (See the page 57)	Without 0 to 1% 0 to 2% 0 to 3% 0 to 5% 0 to 10% 0 to 20% 0 to 25% 0 to 40% 0 to 50% 0 to 70% 0 to 100% Others						Y J K Q L M N V W P X R Z								
11	2nd component, 1st range (See the page 58)	Without 0 to 0.5% 0 to 1% 0 to 2% 0 to 3% 0 to 5% 0 to 10% 0 to 20% 0 to 25% 0 to 40% 0 to 50% 0 to 70% 0 to 100% Others						Y H J K Q L M N V W P X R Z								
12	2nd component, 2nd range (See the page 58)	Without 0 to 1% 0 to 2% 0 to 3% 0 to 5% 0 to 10% 0 to 20% 0 to 25% 0 to 40% 0 to 50% 0 to 70% 0 to 100% Others						Y J K Q L M N V W P X R Z								
13	Display language	Japanese English											1 2			
14	Option	Without With CP calculation value output With Contact input/output With CP calculation value output + Contact input/output												Y A B C		
15	—	—												Y		
16	Adjustment (Note 1)	Standard Heat treatment furnaces (Note 2) Steel converter Others													A B C Z	

Note)
See page 57 to 58 for the possible measuring ranges to be manufactured.

(Table 1 to 3:
Single-component analyzer
Table 4 to 6:
Two-component analyzer)

Note 1)
Calibration curve varies with gas components contained in sample gas.
"A ; standard adjustment" stands for adjustment in N₂ balance.
"B ; adjustment for heat treatment furnace" is applied to CO analyzer and CO₂ analyzer.
CO₂ analyzer: CO₂ range gas + 25% CO + 31% H₂/N₂
CO analyzer: CO range gas + 5% CO₂ + 31% H₂/N₂
When "Z; other" is specified, a gas composition table should be attached.
Note 2)
When the 16th code is "B", the range code "X" and "R" are not available.

Correspondence table of the possible measuring ranges

Table 1: Single-component analyzer <CO₂>

2nd range 1st range		Y	J	K	Q	L	M	N	V	W	P	X	R
		Without	0 to 1%	0 to 2%	0 to 3%	0 to 5%	0 to 10%	0 to 20%	0 to 25%	0 to 40%	0 to 50%	0 to 70%	0 to 100%
H	0 to 0.5%	○	○	○	○	–	–	–	–	–	–	–	–
J	0 to 1%	○	–	○	○	○	–	–	–	–	–	–	–
K	0 to 2%	○	–	–	○	○	○	–	–	–	–	–	–
Q	0 to 3%	○	–	–	–	○	○	–	–	–	–	–	–
L	0 to 5%	○	–	–	–	–	○	○	○	○	○	○	○
M	0 to 10%	○	–	–	–	–	–	○	○	○	○	○	○
N	0 to 20%	○	–	–	–	–	–	–	○	○	○	○	○
V	0 to 25%	○	–	–	–	–	–	–	–	○	○	○	○
W	0 to 40%	○	–	–	–	–	–	–	–	–	○	○	○
P	0 to 50%	○	–	–	–	–	–	–	–	–	–	○	○
X	0 to 70%	○	–	–	–	–	–	–	–	–	–	–	○
R	0 to 100%	○	–	–	–	–	–	–	–	–	–	–	–

Table 2: Single-component analyzer <CO>

2nd range 1st range		Y	J	K	Q	L	M	N	V	W	P	X	R
		Without	0 to 1%	0 to 2%	0 to 3%	0 to 5%	0 to 10%	0 to 20%	0 to 25%	0 to 40%	0 to 50%	0 to 70%	0 to 100%
H	0 to 0.5%	○	○	○	○	–	–	–	–	–	–	–	–
J	0 to 1%	○	–	○	○	○	–	–	–	–	–	–	–
K	0 to 2%	○	–	–	○	○	○	–	–	–	–	–	–
Q	0 to 3%	○	–	–	–	○	○	–	–	–	–	–	–
L	0 to 5%	○	–	–	–	–	○	○	○	○	○	○	○
M	0 to 10%	○	–	–	–	–	–	○	○	○	○	○	○
N	0 to 20%	○	–	–	–	–	–	–	○	○	○	○	○
V	0 to 25%	○	–	–	–	–	–	–	–	○	○	○	○
W	0 to 40%	○	–	–	–	–	–	–	–	–	○	○	○
P	0 to 50%	○	–	–	–	–	–	–	–	–	–	○	○
X	0 to 70%	○	–	–	–	–	–	–	–	–	–	–	○
R	0 to 100%	○	–	–	–	–	–	–	–	–	–	–	–

Table 3: Single-component analyzer <CH₄>

2nd range 1st range		Y	K	Q	L	M	N	V	W	P	X	R
		Without	0 to 2%	0 to 3%	0 to 5%	0 to 10%	0 to 20%	0 to 25%	0 to 40%	0 to 50%	0 to 70%	0 to 100%
J	0 to 1%	○	○	○	○	–	–	–	–	–	–	–
K	0 to 2%	○	–	○	○	○	–	–	–	–	–	–
Q	0 to 3%	○	–	–	○	○	–	–	–	–	–	–
L	0 to 5%	○	–	–	–	○	○	○	○	○	○	○
M	0 to 10%	○	–	–	–	–	○	○	○	○	○	○
N	0 to 20%	○	–	–	–	–	–	○	○	○	○	○
V	0 to 25%	○	–	–	–	–	–	–	○	○	○	○
W	0 to 40%	○	–	–	–	–	–	–	–	○	○	○
P	0 to 50%	○	–	–	–	–	–	–	–	–	○	○
X	0 to 70%	○	–	–	–	–	–	–	–	–	–	○
R	0 to 100%	○	–	–	–	–	–	–	–	–	–	–

Correspondence table of the possible measuring ranges

Table 4: Two-component analyzer <CO₂/CO>

1st component <CO ₂ >		2nd component <CO> 1st range/2nd range																			
1st range/ 2nd range	Code	0 to 0.5 /1%	0 to 1 /2%	0 to 1 /3%	0 to 2 /3%	0 to 2 /5%	0 to 3 /5%	0 to 5 /10%	0 to 10 /20%	0 to 10 /25%	0 to 20 /25%	0 to 20 /40%	0 to 20 /50%	0 to 25 /40%	0 to 25 /50%	0 to 40 /50%	0 to 40 /70%	0 to 50 /70%	0 to 50 /100%	0 to 70 /100%	0 to 100% /Without
		HJ	JK	JQ	KQ	KL	QL	LM	MN	MV	NV	NW	NP	VW	VP	WP	WX	PX	PR	XR	RY
0 to 0.5/1%	HJ	o	o	o	o	o	o	o	o	o	o	o	o	o	o	o	o	o	o	o	o
0 to 1/2%	JK	o	o	o	o	o	o	o	o	o	o	o	o	o	o	o	o	o	o	o	o
0 to 1/3%	JQ	o	o	o	o	o	o	o	o	o	o	o	o	o	o	o	o	o	o	o	o
0 to 2/3%	KQ	o	o	o	o	o	o	o	o	o	o	o	o	o	o	o	o	o	o	o	o
0 to 2/5%	KL	o	o	o	o	o	o	o	o	o	o	o	o	o	o	o	o	o	o	o	o
0 to 3/5%	QL	o	o	o	o	o	o	o	o	o	o	o	o	o	o	o	o	o	o	o	o
0 to 5/10%	LM	-	o	o	o	o	o	o	o	o	o	o	o	o	o	o	o	o	o	o	o
0 to 10/20%	MN	-	-	o	o	o	o	o	o	o	o	o	o	o	o	o	o	o	o	o	o
0 to 10/25%	MV	-	-	-	o	o	o	o	o	o	o	o	o	o	o	o	o	o	o	o	o
0 to 20/25%	NV	-	-	-	o	o	o	o	o	o	o	o	o	o	o	o	o	o	o	o	o
0 to 20/40%	NW	-	-	-	o	o	o	o	o	o	o	o	o	o	o	o	o	o	o	o	o
0 to 20/50%	NP	-	-	-	o	o	o	o	o	o	o	o	o	o	o	o	o	o	o	o	o
0 to 25/40%	VW	-	-	-	o	o	o	o	o	o	o	o	o	o	o	o	o	o	o	o	o
0 to 25/50%	VP	-	-	-	o	o	o	o	o	o	o	o	o	o	o	o	o	o	o	o	o
0 to 40/50%	WP	-	-	-	o	o	o	o	o	o	o	o	o	o	o	o	o	o	o	o	o
0 to 40/70%	WX	-	-	-	o	o	o	o	o	o	o	o	o	o	o	o	o	o	o	o	o
0 to 50/70%	PX	-	-	-	o	o	o	o	o	o	o	o	o	o	o	o	o	o	o	o	o
0 to 50/100%	PR	-	-	-	o	o	o	o	o	o	o	o	o	o	o	o	o	o	o	o	o
0 to 70/100%	XR	-	-	-	o	o	o	o	o	o	o	o	o	o	o	o	o	o	o	o	o
0 to 100%/Without	RY	-	-	-	o	o	o	o	o	o	o	o	o	o	o	o	o	o	o	o	o

Table 5: Two-component analyzer <CO₂/CH₄>

1st component <CO ₂ >		2nd component <CH ₄ > 1st range/2nd range															
1st range/ 2nd range	Code	0 to 2 /3%	0 to 2 /5%	0 to 3 /5%	0 to 5 /10%	0 to 10 /20%	0 to 10 /25%	0 to 20 /40%	0 to 20 /50%	0 to 25 /40%	0 to 25 /50%	0 to 40 /50%	0 to 40 /70%	0 to 50 /70%	0 to 50 /100%	0 to 70 /100%	0 to 100% /Without
		KQ	KL	QL	LM	MN	MV	NV	NW	NP	VW	VP	WP	WX	PX	PR	XR
0 to 1/2%	JK	o	o	o	o	o	o	o	o	o	o	o	o	o	o	o	o
0 to 1/3%	JQ	o	o	o	o	o	o	o	o	o	o	o	o	o	o	o	o
0 to 2/3%	KQ	o	o	o	o	o	o	o	o	o	o	o	o	o	o	o	o
0 to 2/5%	KL	o	o	o	o	o	o	o	o	o	o	o	o	o	o	o	o
0 to 3/5%	QL	o	o	o	o	o	o	o	o	o	o	o	o	o	o	o	o
0 to 5/10%	LM	-	-	-	o	o	o	o	o	o	o	o	o	o	o	o	o
0 to 10/20%	MN	-	-	-	o	o	o	o	o	o	o	o	o	o	o	o	o
0 to 10/25%	MV	-	-	-	o	o	o	o	o	o	o	o	o	o	o	o	o
0 to 20/25%	NV	-	-	-	o	o	o	o	o	o	o	o	o	o	o	o	o
0 to 20/40%	NW	-	-	-	o	o	o	o	o	o	o	o	o	o	o	o	o
0 to 20/50%	NP	-	-	-	o	o	o	o	o	o	o	o	o	o	o	o	o
0 to 25/40%	VW	-	-	-	o	o	o	o	o	o	o	o	o	o	o	o	o
0 to 25/50%	VP	-	-	-	o	o	o	o	o	o	o	o	o	o	o	o	o
0 to 40/50%	WP	-	-	-	o	o	o	o	o	o	o	o	o	o	o	o	o
0 to 40/70%	WX	-	-	-	o	o	o	o	o	o	o	o	o	o	o	o	o
0 to 50/70%	PX	-	-	-	o	o	o	o	o	o	o	o	o	o	o	o	o
0 to 50/100%	PR	-	-	-	o	o	o	o	o	o	o	o	o	o	o	o	o
0 to 70/100%	XR	-	-	-	o	o	o	o	o	o	o	o	o	o	o	o	o
0 to 100%/Without	RY	-	-	-	o	o	o	o	o	o	o	o	o	o	o	o	o

Table 6: Two-component analyzer <CH₄/CO>

1st component <CH ₄ >		2nd component <CO> 1st range/2nd range																			
1st range/ 2nd range	Code	0 to 1 /2%	0 to 1 /3%	0 to 2 /3%	0 to 2 /5%	0 to 3 /5%	0 to 5 /10%	0 to 10 /20%	0 to 10 /25%	0 to 20 /25%	0 to 20 /40%	0 to 20 /50%	0 to 25 /40%	0 to 25 /50%	0 to 40 /50%	0 to 40 /70%	0 to 50 /70%	0 to 50 /100%	0 to 70 /100%	0 to 100% /Without	
		JK	JQ	KQ	KL	QL	LM	MN	MV	NV	NW	NP	VW	VP	WP	WX	PX	PR	XR	RY	
0 to 1/2%	JK	o	o	o	o	o	o	o	o	o	o	o	o	o	o	o	o	o	o	o	o
0 to 1/3%	JQ	o	o	o	o	o	o	o	o	o	o	o	o	o	o	o	o	o	o	o	o
0 to 2/3%	KQ	o	o	o	o	o	o	o	o	o	o	o	o	o	o	o	o	o	o	o	o
0 to 2/5%	KL	o	o	o	o	o	o	o	o	o	o	o	o	o	o	o	o	o	o	o	o
0 to 3/5%	QL	o	o	o	o	o	o	o	o	o	o	o	o	o	o	o	o	o	o	o	o
0 to 5/10%	LM	o	o	o	o	o	o	o	o	o	o	o	o	o	o	o	o	o	o	o	o
0 to 10/20%	MN	o	o	o	o	o	o	o	o	o	o	o	o	o	o	o	o	o	o	o	o
0 to 10/25%	MV	o	o	o	o	o	o	o	o	o	o	o	o	o	o	o	o	o	o	o	o
0 to 20/25%	NV	o	o	o	o	o	o	o	o	o	o	o	o	o	o	o	o	o	o	o	o
0 to 20/40%	NW	o	o	o	o	o	o	o	o	o	o	o	o	o	o	o	o	o	o	o	o
0 to 20/50%	NP	o	o	o	o	o	o	o	o	o	o	o	o	o	o	o	o	o	o	o	o
0 to 25/40%	VW	o	o	o	o	o	o	o	o	o	o	o	o	o	o	o	o	o	o	o	o
0 to 25/50%	VP	o	o	o	o	o	o	o	o	o	o	o	o	o	o	o	o	o	o	o	o
0 to 40/50%	WP	-	-	o	o	o	o	o	o	o	o	o	o	o	o	o	o	o	o	o	o
0 to 40/70%	WX	-	-	o	o	o	o	o	o	o	o	o	o	o	o	o	o	o	o	o	o
0 to 50/70%	PX	-	-	o	o	o	o	o	o	o	o	o	o	o	o	o	o	o	o	o	o
0 to 50/100%	PR	-	-	o	o	o	o	o	o	o	o	o	o	o	o	o	o	o	o	o	o
0 to 70/100%	XR	-	-	o	o	o	o	o	o	o	o	o	o	o	o	o	o	o	o	o	o
0 to 100%/Without	RY	-	-	o	o	o	o	o	o	o	o	o	o	o	o	o	o	o	o	o	o

Fuji Electric Co., Ltd.

Instrumentation & Sensors Planning Dept.
1, Fuji-machi, Hino-city, Tokyo 191-8502, Japan
<http://www.fujielectric.com>
Phone: +81-42-514-8930 Fax: +81-42-583-8275
<http://www.fujielectric.com/products/instruments/>
