

Pressurized Systems



APEX Control unit	APEX ^{px}	APEX ^{py}	APEX ^{px}	APEX ^{py}	APEX 2003
Power supply	DC 24 V to 44 V or AC 100 V to 240 V	DC 24 V to 44 V or AC 100 V to 240 V	DC 24 V to 44 V or AC 100 V to 240 V	DC 24 V to 44 V or AC 100 V to 240 V	DC 24 V, AC 115 V or AC 230 V
Safety integrity level	SIL 2	SIL 2	SIL 2	SIL 2	SIL 2
Inputs	3 x PT100/1000 Bypass Main switch 1 x 4 – 20 mA [Ex ib] 1 x 4 – 20 mA [Ex ia]	3 x PT100/1000 Bypass Main switch 1 x 4 – 20 mA [Ex ib] 1 x 4 – 20 mA [Ex ia]	3 x PT100/1000 Bypass Main switch 1 x 4 – 20 mA [Ex ib] 1 x 4 – 20 mA [Ex ia]	3 x PT100/1000 Bypass Main switch 1 x 4 – 20 mA [Ex ib] 1 x 4 – 20 mA [Ex ia]	Temperature switch Bypass Main switch
Outputs	1 x release 1 x release, 4 NO 2 x signal relays, CO 1 x inlet valve 1 x outlet valve	1 x release 1 x release, 4 NO 2 x signal relays, CO 1 x inlet valve 1 x outlet valve	1 x release 1 x release, 4 NO 2 x signal relays, CO 1 x inlet valve 1 x outlet valve	1 x release 1 x release, 4 NO 2 x signal relays, CO 1 x inlet valve 1 x outlet valve	1 x release 2 x signal relays, 1 CO, 3 NO 1 x inlet valve 1 x outlet valve
Interface	Ethernet	Ethernet	Ethernet	Ethernet	–
Valve control	Proportional or digital	Proportional or digital	Proportional or digital	Proportional or digital	Proportional or digital
Additionally required system components	Sensor box px Pressure monitor Purge gas valve Valve fuse Pressure reducer	Sensor box py Pressure monitor Purge gas valve Valve fuse Pressure reducer	Pressure monitor Purge gas valve Valve fuse Pressure reducer	Pressure monitor Purge gas valve Valve fuse Pressure reducer	Purge gas valve Pressure reducer
Pressure measurement	Separate 0 to 25 mbar 0 to 300 mbar	Separate 0 to 25 mbar 0 to 300 mbar	Integrated 0 to 25 mbar 0 to 300 mbar	Integrated 0 to 25 mbar 0 to 300 mbar	Integrated 0 to 25 mbar
Display	Optional	Optional	Optional	Optional	Integrated
Ambient temperature	-25 °C to +70 °C	-25 °C to +70 °C	-25 °C to +70 °C	-25 °C to +70 °C	-20 °C to +40 °C
Application	Gas, dust	Gas, dust	Gas, dust	Gas, dust	Gas
Approvals	ATEX, IECEx	ATEX, IECEx	ATEX, IECEx	ATEX, IECEx	ATEX, IECEx, EAC-Ex, Kosha, CSA, INMETRO
Additional components (optional)	p operator panel Polaris SMART HMI	p operator panel Polaris SMART HMI	p operator panel Polaris SMART HMI	p operator panel Polaris SMART HMI	–
Variants					Various models
Type	07-37A2-2211/x510	07-37A2-2111/x510	07-37A2-2211/x520	07-37A2-2111/x520	07-3711-12xx/xxxx
Dimensions	W x H x D 250 mm x 250 mm x 130 mm	W x H x D 250 mm x 250 mm x 130 mm	W x H x D 250 mm x 300 mm x 130 mm	W x H x D 250 mm x 300 mm x 130 mm	Depends on the version
Product status	Market launch	Market launch	Market launch	Market launch	



SILAS Control unit	SILAS ^{pz}	SILAS ^{pz}	SILAS
Power supply	DC 24 V to 44 V or AC 100 V to 240 V	DC 24 V to 44 V or AC 100 V to 240 V	DC 24 V, AC 115 V or AC 230 V
Inputs	3 x PT100/1000 Bypass Main switch	3 x PT100/1000 Bypass Main switch	Bypass jumper (internal)
Outputs	1 x release 1 x release, 4 NO 2 x signal relays, CO 1 x inlet valve	1 x release 1 x release, 4 NO 2 x signal relays, CO 1 x inlet valve	1 x release relay 1 x alarm relay 1 x inlet valve
Interface	Ethernet	Ethernet	–
Valve control	Proportional or digital	Proportional or digital	Digital
Additionally required system components	Sensor box pz Pressure monitor Purge gas valve Valve fuse Pressure reducer	Pressure monitor Purge gas valve Valve fuse Pressure reducer	Purge gas valve Pressure monitor Pres- sure reducer
Pressure measurement	Separate 0 to 25 mbar 0 to 300 mbar	Integrated 0 to 25 mbar 0 to 300 mbar	Integrated 0 to 25 mbar
Display	Optional	Optional	Integrated
Ambient temperature	-25 °C to +70 °C	-25 °C to +70 °C	-20 °C to +60 °C
Application	Gas, dust	Gas, dust	Gas, dust (IIIB)
Approvals	ATEX, IECEx	ATEX, IECEx	ATEX, IECEx, EAC-Ex, Kosha, CSA, INMETRO
Additional components (optional)	p operator panel Polaris SMART HMI	p operator panel Polaris SMART HMI	–
Variants			
Type	A7-37S2-2111/x510	A7-37S2-2111/x520	A7-3741-1110/x00x
Dimensions	W x H x D 250 mm x 250 mm x 130 mm	W x H x D 250 mm x 300 mm x 130 mm	W x H x D 90 mm x 120 mm x 60 mm
Product status	Market launch	Market launch	

Zones 1, 21



Zones 2, 22



MODEL	APEX ^{mpc}	SILAS ^{mpc}
Power supply	DC 24 V to 44 V or AC 100 V to 240 V	DC 24 V to 44 V or AC 100 V to 240 V
Inputs	3 x PT100/1000 Bypass Main switch	3 x PT100/1000 Bypass Main switch
Outputs	1 x release 1 x release, 4 NO 2 x signal relays, CO	1 x release 1 x release, 4 NO 2 x signal relays, CO
Interface	Ethernet	Ethernet
Purge gas valve	Digital purge gas valve (purging) Proportional valve (leakage compensation)	Digital purge gas valve (purging) Throttle valve, mechanical (leakage compensation)
Pressure measurement	Integrated 0 to 25 mbar 0 to 300 mbar	Integrated 0 to 25 mbar 0 to 300 mbar
Display	Optional	Optional
Ambient temperature	-25 °C – +50 °C (standard) -50 °C – +50 °C (high-temperature)	-25 °C – +50 °C (standard) -50 °C – +50 °C (high-temperature)
Application	Gas, dust	Gas, dust
Approvals	ATEX, IECEx	ATEX, IECEx
Additional components (optional)	p operator panel Polaris SMART HMI	p operator panel Polaris SMART HMI

Variants

Type	07-37A2-2211/xM5x	07-37S2-2111/xM5x
Dimensions	W x H x D 550 mm x 400 mm x 250 mm	W x H x D 550 mm x 400 mm x 250 mm
Product status	Market launch	Market launch

APEX for analysis systems (containment systems)

APEX (separate unit)



MODEL	APEX ^{cf}	APEX ^{dp}	APEX 2003.SI	APEX ^{mv} /SILAS ^{mv}	APEX 2003.MV
	Continuous purging cf = continuous flow	High-pressure system dp = dynamic pressure		Separate equipment mv = with valve	Separate equipment mv = with valve
Power supply	DC 24 V to 44 V or AC 100 V to 240 V	DC 24 V to 44 V or AC 100 V to 240 V	DC 24 V, AC 115 V or AC 230 V	DC 24 V to 44 V or AC 100 V to 240 V	DC 24 V, AC 115 V or 230 V AC
Safety integrity level	SIL 2	SIL 2	SIL 2	SIL 2	SIL 2
Inputs	3 x PT100/1000 Bypass Main switch 1 x 4 to 20 mA [Ex ib] 1 x 4 to 20 mA [Ex ia]	3 x PT100/1000 Bypass Main switch 1 x 4 to 20 mA [Ex ib] 1 x 4 to 20 mA [Ex ia]	Temperature switch Bypass Main switch	APEX: 3 x PT100/1000 Bypass Main switch 1 x 4 to 20 mA [Ex ib] 1 x 4 to 20 mA [Ex ia] SILAS: 3 x PT100/1000 Bypass Main switch	Temperature switch Bypass Main switch
Outputs	1 x release 1 x release, 4 NO 2 x signal relays, CO	1 x release 1 x release, 4 NO 2 x signal relays, CO	1 x release 2 x signal relays, 1 CO, 3 NO	1 x release 1 x release, 4 NO 2 x signal relays, CO	1 x release 2 x signal relays, 1 CO, 3 NO
Interface	Ethernet	Ethernet	–	Ethernet	–
Valve control	Proportional, integrated	Proportional, integrated	Proportional or digital	Proportional, integrated	Proportional, integrated
Pressure measurement	Integrated 0 – 25 mbar	Integrated 0 – 300 mbar	Integrated 0 – 25 mbar 0 – 300 mbar	Integrated 0 – 25 mbar	Integrated 0 – 25 mbar
Display	Optional	Optional	Integrated	Optional	Integrated
Ambient temperature	-25 °C to +50 °C	-25 °C to +50 °C	-20 °C to +40 °C	-25 °C to +50 °C	-20 °C to +40 °C
Application	Containment system Gas, dust With constant flow rate during the operating phase Separate unit for p volume of up to 70 litres	Containment system Gas, dust With dynamic Δp regulation Separate unit for p volume of up to 70 litres	Containment system Gas Separate unit for p volume of up to 70 litres	Gas, dust Separate unit for p volume of up to 70 litres	Gas Separate unit for p volume of up to 70 litres
Approvals	ATEX, IECEx	ATEX, IECEx	ATEX, EAC-Ex, KTL, CSA	ATEX, IECEx	ATEX, EAC-Ex, KTL,
Additional components (optional)	p operator panel Polaris SMART HMI	p operator panel Polaris SMART HMI	–	p operator panel Polaris SMART HMI	–
Type	07-37A2-2211/x725	07-37A2-2211/x720	07-3711-x2x3/xxxx	07-37A2-2211/x730	A7-37S2-2111/x730
Dimensions	W x H x D 400 mm x 300 mm x 130 mm	W x H x D 400 mm x 300 mm x 130 mm	W x H x D 400 mm x 250 mm x 120 mm	W x H x D 400 mm x 300 mm x 130 mm	W x H x D 255 mm x 250 mm x 120 mm
Product status	Market launch	Market launch		Market launch	



- Black box system
- Automatic calculation of the purge time
- WEB interface
- 3 x PT100/1000 inputs
- Modular design
- Safety-related control system
- Separate purge gas input and output

SIL 2

Explosion protection

ATEX marking	Ⓜ II 2(1)G Ex eb mb ib [ib pxb] [ia Ga] IIC T5, T4 Gb Ⓜ II 2(1)D Ex tb [ib pxb] [ia Da] IIIC T95 °C, T130 °C Db
Certification	BVS 19 ATEX E 015
IECEX marking	Ex eb mb ib [ib pxb] [ia Ga] IIC T5, T4 Gb Ex tb [ib pxb] [ia Da] IIIC T95 °C, T130 °C Db
Certification	IECEX BVS 19.0038X
Other approvals and certificates, see www.bartec.com	
Ambient temperature	In storage -20 °C to +60 °C During operation -25 °C to +60 °C/T4 -25 °C to +50 °C/T5

Technical data

Directives	Directive 2014/30/EU Directive 2014/34/EU
Structure	Ex e protective housing with integrated Ex mb/ib-protected p control system
Housing material	V4A stainless steel
IP rating	IP 66 according to EN/IEC 60529 IP 64 according to EN/IEC 60079-0
Terminals	Ex e: 0.08 to 2.5 mm ² , fine-wire, tension spring Ex i: 0.2 to 1.5 mm ² , fine-wire, push-in
Pressure measurement range	0 to 25 mbar (standard) or 0 to 300 mbar (on request)
Pre-purge time	0 to 120 min
Weight	5.8 kg
Safety integrity level	SIL 2

The APEX^{px} Ex p control unit controls and monitors the pre-purge and operating phase of pressurised enclosure equipment protected in accordance with ignition protection type px. Digital or proportional purge gas valves can be used as purge gas valves. The parameters can be set using the integrated WEB interface or the optionally available p operator panel. The APEX^{px} features two release relays; one which is energised and one which has floating contacts. Two signal relays with one changeover contact each are additionally available. Three PT100/1000 inputs are available to monitor the temperature of the Ex p-protected equipment. Up to three switch values can be assigned to them. Model I comes complete with separate pressure measurement.

The following components are additionally required to set up a complete control system:

- Sensor box^{px}
- Pressure monitor
- Purge gas valve, proportional or digital
- Valve fuse
- Pressure reducer
- There is the option to connect a p operator panel

Electrical data

Supply voltage	24 V DC to 44 V DC, ±10% or 100 V AC to 230 V AC, ±10%
Power consumption	Pv = approx. 19 watts
Normally open contacts	K1 (SIL) release, max. 5 A (AC1) K2 (SIL) release, floating, max. 230 V AC/3 A (AC1) K3 and K4 signal relays, floating, changeover contact, max. 1 A (AC1)
Inputs	3 x PT100/1000 1 x bypass 1 x main switch 1 x 4 to 20 mA [ib] – pressure sensor 1 x 4 to 20 mA [ia] – pressure sensor

Dimensions

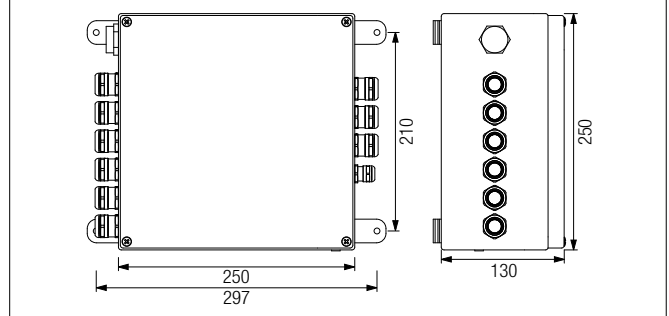

Ordering information

	Code no.
24 V DC to 44 V DC, ±10 %	1
100 V AC to 230 V AC, ±10 %	2

Complete order no. 07-37A2-2211/□510

Please enter code number.

The accessories and order information can be found on the accessory pages.

Technical data subject to change without notice.



- Black box system
- Automatic calculation of the purge time
- WEB interface
- 3 x PT100/1000 inputs
- Modular design
- Safety-related control system
- Separate purge gas input and output

SIL 2

Explosion protection

ATEX marking	⊕ II 2(1)G Ex eb mb ib [ib pxb] [ia Ga] IIC T5, T4 Gb ⊕ III 2(1)D Ex tb [ib pxb] [ia Da] IIIC T95 °C, T130 °C Db
Certification	BVS 19 ATEX E 015
IECEX marking	Ex eb mb ib [ib pxb] [ia Ga] IIC T5, T4 Gb Ex tb [ib pxb] [ia Da] IIIC T95 °C, T130 °C Db
Certification	IECEX BVS 19.0038X
Other approvals and certificates, see www.bartec.com	
Ambient temperature	In storage -20 °C to +60 °C During operation -25 °C to +60 °C/T4 -25 °C to +50 °C/T5

Technical data

Directives	Directive 2014/30/EU Directive 2014/34/EU
Structure	Ex e protective housing with integrated Ex mb/ib-protected p control system
Housing material	V4A stainless steel
IP rating	IP 66 according to EN/IEC 60529 IP 64 according to EN/IEC 60079-0
Terminals	Ex e: 0.08 to 2.5 mm ² , fine-wire, tension spring Ex i: 0.2 to 1.5 mm ² , fine-wire, push-in
Pneumatic connections	2 x hoses, 4 mm dia.
Pressure measurement range	0 to 25 mbar (standard) or 0 to 300 mbar (on request)
Pre-purge time	0 to 120 min
Weight	6.8 kg

The APEX^{px} Ex p control unit controls and monitors the pre-purge and operating phase of pressurised enclosure equipment protected in accordance with ignition protection type px. Digital or proportional purge gas valves can be used as purge gas valves. The parameters can be set using the integrated WEB interface or the optionally available p operator panel. The APEX^{px} features two release relays; one which is energised and one which has floating contacts. Two signal relays with one changeover contact each are additionally available. Three PT100/1000 inputs are available to monitor the temperature of the Ex p-protected equipment. Up to three switch values can be assigned to them. Model II comes complete with integrated pressure measurement. The following components are additionally required to set up a complete control system:

- Pressure monitor
- Purge gas valve, proportional or digital
- Valve fuse
- Pressure reducer
- There is the option to connect a p operator panel

Safety integrity level	SIL 2
------------------------	-------

Electrical data

Supply voltage	24 V DC to 44 V DC, ±10 % or 100 V AC to 230 V AC, ±10 %
Power consumption	Pv = approx. 19 watts
Normally open contacts	K1 (SIL) release, max. 5 A (AC1) K2 (SIL) release, floating, max. 230 V AC/3 A (AC1) K3 and K4 signal relays, floating, changeover contact, max. 1 A (AC1)
Inputs	3 x PT100/1000 1 x bypass 1 x main switch 1 x 4 to 20 mA [ib] – pressure sensor 1 x 4 to 20 mA [ia] – pressure sensor

Dimensions

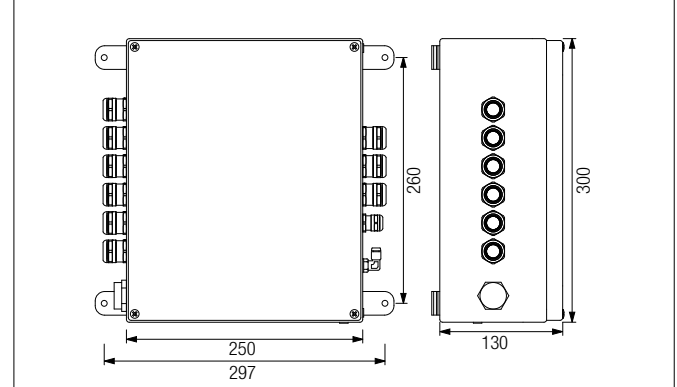

Ordering information	Code no.
24 V DC to 44 V DC, ±10 %	1
100 V AC to 230 V AC, ±10 %	2

Complete order no. 07-37A2-2211/ 520

Please enter code number.

The accessories and order information can be found on the accessory pages. Technical data subject to change without notice.



- Black box system
- Automatic calculation of the purge time
- WEB interface
- 3 x PT100/1000 inputs
- Modular design
- Safety-related control system
- Separate purge gas input and output

SIL 2

The APEX^{py} Ex p control unit controls and monitors the pre-purge and operating phase of pressurised enclosure equipment protected in accordance with ignition protection type py. Digital or proportional purge gas valves can be used as purge gas valves. The parameters can be set using the integrated WEB interface or the optionally available p operator panel. The APEX^{py} features two release relays; one which is energised and one which has floating contacts. Two signal relays with one changeover contact each are additionally available. Three PT100/1000 inputs are available to monitor the temperature of the Ex p-protected equipment. Up to three switch values can be assigned to them. Model I comes complete with separate pressure measurement. The following components are additionally required to set up a complete control system:

- Sensor box^{PK}
- Pressure monitor
- Purge gas valve, proportional or digital
- Valve fuse
- Pressure reducer
- There is the option to connect a p operator panel

Explosion protection

ATEX marking	Ⓜ II 2(1)G Ex eb mb ib [ib pyb] [ia Ga] IIC T5, T4 Gb Ⓜ II 2(1)D Ex tb [ib pyb] [ia Da] IIIC T95 °C, T130 °C Db
Certification	BVS 19 ATEX E 015
IECEX marking	Ex eb mb ib [ib pyb] [ia Ga] IIC T5, T4 Gb Ex tb [ib pyb] [ia Da] IIIC T95 °C, T130 °C Db
Certification	IECEX BVS 19.0038X
Other approvals and certificates, see www.bartec.com	
Ambient temperature	In storage -20 °C to +60 °C During operation -25 °C to +60 °C/T4 -25 °C to +50 °C/T5

Technical data

Directives	Directive 2014/30/EU Directive 2014/34/EU
Structure	Ex e protective housing with integrated Ex mb/ib-protected p control system
Housing material	V4A stainless steel
IP rating	IP 66 according to EN/IEC 60529 IP 64 according to EN/IEC 60079-0
Terminals	Ex e: 0.08 to 2.5 mm ² , fine-wire, tension spring Ex i: 0.2 to 1.5 mm ² , fine-wire, push-in
Pressure measurement range	0 to 25 mbar (standard) or 0 to 300 mbar (on request)
Pre-purge time	0 to 120 min
Weight	5.8 kg
Safety integrity level	SIL 2

Electrical data

Supply voltage	24 V DC to 44 V DC, ±10 % or 100 V AC to 230 V AC, ±10 %
Power consumption	Pv = approx. 19 watts
Normally open contacts	K1 (SIL) release, max. 5 A (AC1) K2 (SIL) release, floating, max. 230 V AC/3 A (AC1) K3 and K4 signal relays, floating, changeover contact, max. 1 A (AC1)
Inputs	3 x PT100/1000 1 x bypass 1 x main switch 1 x 4 to 20 mA [ib] – pressure sensor 1 x 4 to 20 mA [ia] – pressure sensor

Dimensions

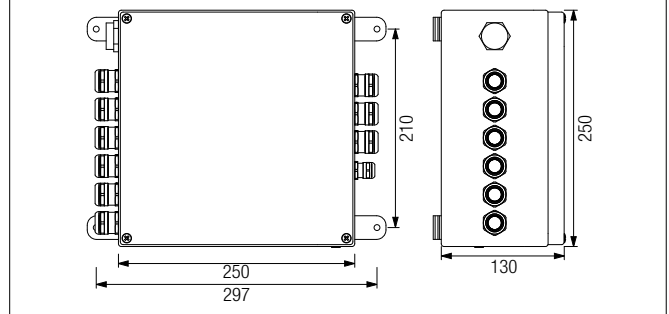

Ordering information

	Code no.
24 V DC to 44 V DC, ±10 %	1
100 V AC to 230 V AC, ±10 %	2

Complete order no. 07-37A2-2111/□ 510

Please enter code number.

The accessories and order information can be found on the accessory pages. Technical data subject to change without notice.



- Pressure monitor
- Purge gas valve, proportional or digital
- Valve fuse
- Pressure reducer
- There is the option to connect a p operator panel
- Separate purge gas input and output

SIL 2

The APEX^{py} Ex p control unit controls and monitors the pre-purge and operating phase of pressurised enclosure equipment protected in accordance with ignition protection type py. Digital or proportional purge gas valves can be used as purge gas valves. The parameters can be set using the integrated WEB interface or the optionally available p operator panel. The APEX^{py} features two release relays; one which is energised and one which has floating contacts. Two signal relays with one changeover contact each are additionally available. Three PT100/1000 inputs are available to monitor the temperature of the Ex p-protected equipment. Up to three switch values can be assigned to them. Model II comes complete with integrated pressure measurement. The following components are additionally required to set up a complete control system:

- Pressure monitor
- Purge gas valve, proportional or digital
- Valve fuse
- Pressure reducer
- There is the option to connect a p operator panel

Explosion protection

ATEX marking	Ⓜ II 2(1)G Ex eb mb ib [ib pyb] [ia Ga] IIC T5, T4 Gb Ⓜ II 2(1)D Ex tb [ib pyb] [ia Da] IIIC T95 °C, T130 °C Db
Certification	BVS 19 ATEX E 015
IECEX marking	Ex eb mb ib [ib pyb] [ia Ga] IIC T5, T4 Gb Ex tb [ib pyb] [ia Da] IIIC T95 °C, T130 °C Db
Certification	IECEX BVS 19.0038X
Other approvals and certificates, see www.bartec.com	
Ambient temperature	In storage -20 °C to +60 °C During operation -25 °C to +60 °C/T4 -25 °C to +50 °C/T5

Technical data

Directives	Directive 2014/30/EU Directive 2014/34/EU
Structure	Ex e protective housing with integrated Ex mb/ib-protected p control system
Housing material	V4A stainless steel
IP rating	IP 66 according to EN/IEC 60529 IP 64 according to EN/IEC 60079-0
Terminals	Ex e: 0.08 to 2.5 mm ² , fine-wire, tension spring Ex i: 0.2 to 1.5 mm ² , fine-wire, push-in
Pneumatic connections	2 x hoses, 4 mm dia.
Pressure measurement range	0 to 25 mbar (standard) or 0 to 300 mbar (on request)
Pre-purge time	0 to 120 min
Weight	6.8 kg
Safety integrity level	SIL 2

Electrical data

Supply voltage	24 V DC to 44 V DC, ±10 % or 100 V AC to 230 V AC, ±10 %
Power consumption	Pv = approx. 19 watts
Normally open contacts	K1 (SIL) release, max. 5 A (AC1) K2 (SIL) release, floating, max. 230 V AC/3 A (AC1) K3 and K4 signal relays, floating, changeover contact, max. 1 A (AC1)
Inputs	3 x PT100/1000 1 x bypass 1 x main switch 1 x 4 to 20 mA [ib] – pressure sensor 1 x 4 to 20 mA [ia] – pressure sensor

Dimensions

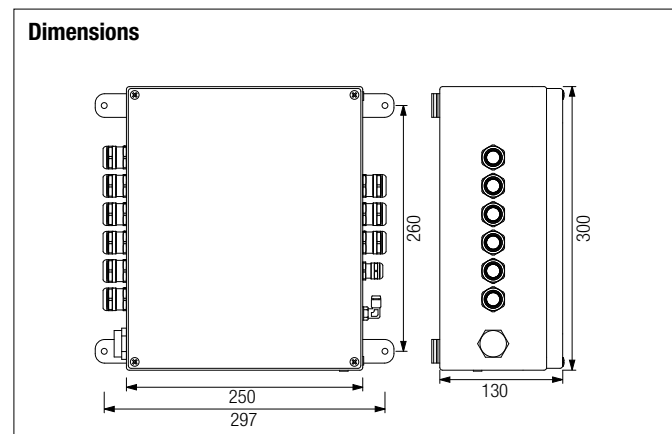

Ordering information

	Code no.
24 V DC to 44 V DC, ±10 %	1
100 V AC to 230 V AC, ±10 %	2

Complete order no. 07-37A2-2111/ 520

Please enter code number.

The accessories and order information can be found on the accessory pages. Technical data subject to change without notice.



- Four floating contacts
- Three-line LCD
- LED status indicator
- Modular design
- Safety-related control system
- Separate purge gas input and output
- Separate display

The APEX 2003.00I Ex p control unit controls and monitors the pre-purge and operating phase of pressurised enclosure equipment protected in accordance with ignition protection type px. Digital or proportional purge gas valves can be used as purge gas valves. The parameters are adjusted using rotary switches and keys. The control unit features two programmable relays and one non-floating release contact. The control unit is designed for internal installation in p-protected equipment, and the following components are required to set up a complete control system:

- Sensor module
- Pressure monitor
- Purge gas valve, proportional or digital, depending on the version
- Pressure reducer

Explosion protection

ATEX marking	⊕ II 2(1)G Ex db eb ib [ia Ga] [p] IIC T4 Gb
Certification	DMT 99 ATEX E 082
IECEX marking	Ex d e ib [ia Ga px] IIC T4 Gb
Certification	IECEX BVS 13.0039
Other approvals and certificates, see www.bartec.com	
Ambient temperature	During operation -20 °C to +40 °C

Technical data

Directives	Directive 2014/30/EU Directive 2014/34/EU
Structure	Ex e protective housing
Housing material	Fibreglass-reinforced polyester
IP rating	IP 65
Terminals	2.5 mm ² , fine-wire
Pressure measurement range	0 to 25 mbar (standard)
Pre-purge time	0 to 99 min, 5 sec dropout delay
Weight	3.8 kg
Safety integrity level	SIL 2

Electrical data

Supply voltage	230 V AC (115 V AC), ±10 % or 24 V DC, ±10 %
Power consumption	Pv = 8 watts
Normally open contacts	K2/3, 5 A when cos φ = 1, K4 and K54, floating

Dimensions

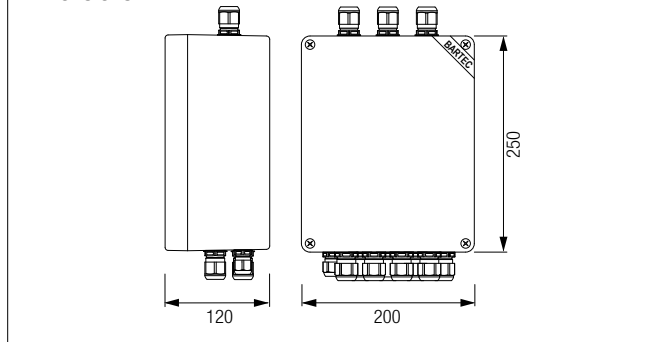

Ordering information

		Code no.
9 W version	230 V AC	1
	115 V AC	2
	24 V DC	4

Complete order no. 07-3711-1200/ 010
Please insert code number.

Ordering information

		Code no.
15 W version	230 V	1
	115 V	2

Complete order no. 07-3711-1200/ 099
Please insert code number.
Technical data subject to change without notice.



- Four floating contacts
- Three-line LCD
- LED status indicator
- Modular design
- Safety-related control system

The APEX 2003.00 control unit controls and monitors the pre-purge and operating phase of pressurised enclosure housings. Digital or proportional purge gas valves can be used to input purge gas. The parameters are adjusted using rotary switches and keys. There is the option to transmit the parameters via an RS485 interface. The control unit features two programmable relays and one non-floating release contact.

Explosion protection

ATEX marking	Ⓔ II 2(1)G Ex db eb ib [ia Ga] [pxb] IIC T4 Gb
Certification	DMT 99 ATEX E 082
IECEX marking	Ex d e ib [ia Ga px] IIC T4 Gb
Certification	IIECEX BVS 13.0039
Other approvals and certificates, see www.bartec.com	
Ambient temperature	-20 °C to +40 °C

Technical data

Directives	Directive 2014/30/EU Directive 2014/34/EU
Structure	Ex e protective housing with viewing pane in the cover
Housing material	Fibreglass-reinforced polyester
IP rating	IP 65
Terminals	2.5 mm ² , fine-wire
Pressure sensors	MIN. A/B = 0 to 25 mbar MAX. = 0 to 25 mbar DIFF. A/B = 0 to 25 mbar
Pre-purge time	0 to 99 min; 5 sec dropout delay
Weight	4.3 kg
Safety integrity level	SIL 2

Electrical data

Supply voltage	230 V AC (115 V AC) ±10 % 24 V DC ±10 %
Power consumption	P _v = 15 W/230 V
Normally open contacts	K 2/3, 5 A when cos φ = 1 K 4 and K 5; floating
Temperature switch value (optional)	0 °C to +80 °C
Bypass key switch (optional)	

Dimensions

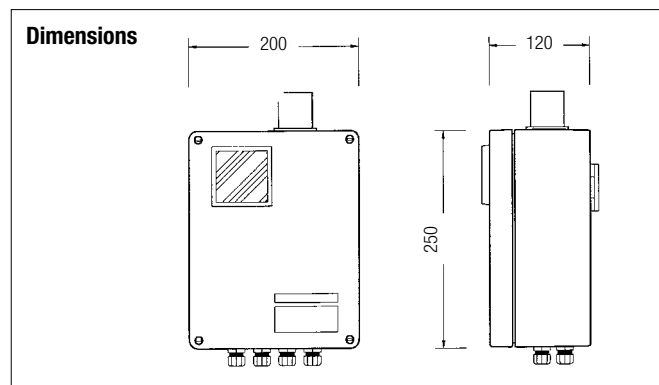

Ordering information

9 W version	Orifice plate	Code no.	Version	Code no.
	12 mm	4	230 V AC	1
	15 mm	5	115 V AC	2
	18 mm	6	24 V DC	4

Complete oder no. 07-3711-121□ / □ 000
Please insert code number.

Ordering information

15 W version	Orifice plate	Code no.	Version	Code no.
	12 mm	4	230 V	1
	15 mm	5	115 V	2
	18 mm	6		

Complete oder no. 07-3711-121□ / □ 082
Please insert code number.

Technical data subject to change without notice.



- Four floating contacts
- Three-line LCD
- LED status indicator
- Modular design
- Safety-related control system

The APEX 2003.002x control unit controls and monitors the pre-purge and operating phase of pressurised enclosure housings. Digital or proportional purge gas valves can be used to input purge gas. The parameters are adjusted using rotary switches and keys. There is the option to transmit the parameters via an RS485 interface. The control unit features two programmable relays and one non-floating release contact.

Explosion protection

ATEX marking	Ⓔ II 2(1)G Ex db eb ib [ia Ga] [pxb] IIC T4 Gb
Certification	DMT 99 ATEX E 082
IECEX marking	Ex d e ib [ia Ga px] IIC T4 Gb
Certification	IECEX BVS 13.0039
Other approvals and certificates, see www.bartec.com	
Ambient temperature	-20 °C to +40 °C

Technical data

Directives	Directive 2014/30/EU Directive 2014/34/EU
Structure	Ex e protective housing with viewing pane in the cover
Housing material	Fibreglass-reinforced polyester
IP rating	IP 65
Terminals	2.5 mm ² , fine-wire
Pressure sensors	MIN. A/B = 0 to 25 mbar MAX. = 0 to 25 mbar DIFF. A/B = 0 to 25 mbar
Pre-purge time	0 to 99 min; 5 sec dropout delay
Weight	7.5 kg
Safety integrity level	SIL 2

Electrical data

Supply voltage	230 V AC (115 V AC) ±10 % 24 V DC ±10 %
Power consumption	P _v = 15 W/230 V
Normally open contacts	K 2/3, 5 A when cos φ = 1 K 4 and K 5; floating
Temperature switch value (optional)	0 °C to +80 °C
Bypass key switch (optional)	

Dimensions

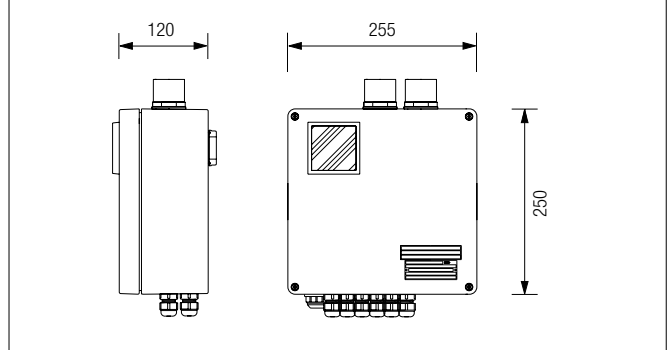

Ordering information

		Code no.
9 W version	230 V AC	1
	115 V AC	2
	24 V DC	4

Complete oder no. 07-3711-1216/ 017
Please insert code number.

Ordering information

		Code no.
15 W version	230 V AC	1
	115 V AC	2

Complete oder no. 07-3711-1216/ 107
Please insert code number.

Technical data subject to change without notice.



- Black box system
- Automatic calculation of the purge time
- Adjustable continuous flow, automatically adjustable
- WEB interface
- 3 x PT100/1000 inputs
- Safety-related control system

SIL 2

Explosion protection

ATEX marking	Ⓜ II 2(1)G Ex eb mb ib [ib pxb] [ia Ga] IIC T4 Gb Ⓜ II 2(1)D Ex tb [ib pxb] [ia Da] IIIC T130 °C Db
Certification	BVS 18 ATEX E 015
IECEx marking	Ex eb mb ib [ib pxb] [ia Ga] IIC T4 Gb Ex tb [ib pxb] [ia Da] IIIC T130 °C Db
Certification	IECEx BVS 19.0038X
Other approvals and certificates, see www.bartec.com	
Ambient temperature	In storage -20 °C to +60 °C During operation -25 °C to +50 °C

Technical data

Directives	Directive 2014/30/EU Directive 2014/34/EU
Structure	Ex e protective housing with integrated Ex mb/ib-protected p control system
Housing material	V4A stainless steel
IP rating	IP 66 according to EN/IEC 60529 IP 64 according to EN/IEC 60079-0
Terminals	Ex e: 0.08 to 2.5 mm ² , fine-wire, tension spring Ex i: 0.2 to 1.5 mm ² , fine-wire, push-in
Pneumatic connections	2 x pipe connections, 10 mm dia.
Pressure measurement range	0 to 25 mbar
Continuous purging	Adjustable, 0 to 20 l/min
Orifice plate size	8 mm
Max. flow rate	6000 l/h
Pre-purge time	0 to 120 min
Weight	6.8 kg
Safety integrity level	SIL 2

The APEX^{cf} Ex p control unit controls and monitors the pre-purge and operating phase of pressurised enclosure equipment with integrated containment, protected in accordance with ignition protection type px, and additionally features an adjustable continuous flow during the operating phase. The parameters can be set using the integrated WEB interface or the optionally available p operator panel. The APEX^{cf} features two release relays; one which is energised and one which has floating contacts. Two signal relays with one changeover contact each are additionally available. Three PT100/1000 inputs are available to monitor the temperature of the Ex p-protected equipment. Up to three switch values can be assigned to them. The design of the APEX^{cf} means that all components required for the pressurised enclosure are located in the control unit. The equipment to be monitored is connected to the Ex p control unit by means of a pipe, which allows a maximum purge volume of 70 litres, maintains overpressure and performs constant purging with a defined volume of purge gas. The following components can also be connected:

- There is the option to connect a p operator panel

Electrical data

Supply voltage	24 V DC to 44 V DC, ±10 % or 100 V AC to 230 V AC, ±10 %
Power consumption	P _v = approx. 19 watts
Normally open contacts	K1 (SIL) release, max. 5 A (AC1) K2 (SIL) release, floating, max. 230 V AC/3 A (AC1) K3 and K4 signal relays, floating, changeover contact, max. 1 A (AC1)
Inputs	3 x PT100/1000 1 x bypass 1 x main switch 1 x 4 to 20 mA [ib] – pressure sensor 1 x 4 to 20 mA [ia] – pressure sensor

Dimensions

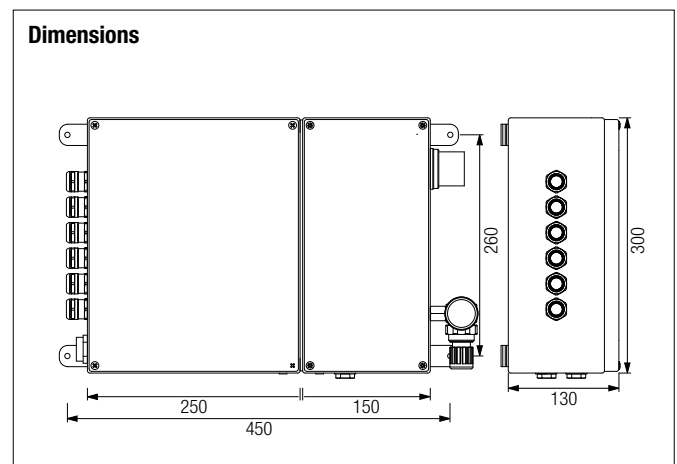

Ordering information

	Code no.
24 V DC to 44 V DC, ±10 %	1
100 V AC to 230 V AC, ±10 %	2

Complete order no. 07-37A2-2211/ 725

Please insert code number.

The accessories and order information can be found on the accessory pages. Technical data subject to change without notice.



- Four floating contacts
- Three-line LCD
- LED status indicator
- Safety-related control system
- Integrated multiport valves for purge gas inlet

The APEX 2003.SI control unit controls and monitors the pre-purge and operating phase of Ex p-protected analysis systems with integrated containment.

Additional function:

During the pre-purge phase, the maximum purge gas flow rate is 4100 NL/h. During the operating phase, continuous purging at a rate of 5 litres/minute is set via a bypass. The control unit features two freely programmable relays and one non-floating release contact.

Explosion protection

ATEX marking	Ⓔ II 2(1)G Ex d e ib [ja Ga px] IIC T4 Gb
Certification	DMT 99 ATEX E 082
Other approvals and certificates, see www.bartec.com	
Ambient temperature	-20 °C to +40 °C

Technical data

Directives	Directive 2014/30/EU Directive 2014/34/EU
Structure	Ex e protective housing
Housing material	Fibreglass-reinforced polyester
IP rating	IP 65
Terminals	2.5 mm ² , fine-wire
Purge gas connection	10 mm dia.
Pressure measurement range	0 to 25 mbar (standard)
Pre-purge time	0 to 99 min; 5 sec dropout delay
Weight	11 kg
Safety integrity level	SIL 2

Electrical data

Supply voltage	230 V AC (115 V AC), ±10 % or 24 V DC, ±10 %
Power consumption	P _v = 15 W
Normally open contacts	K 2/3, 5 A when cos φ = 1 K 4 and K 5; floating

Dimensions

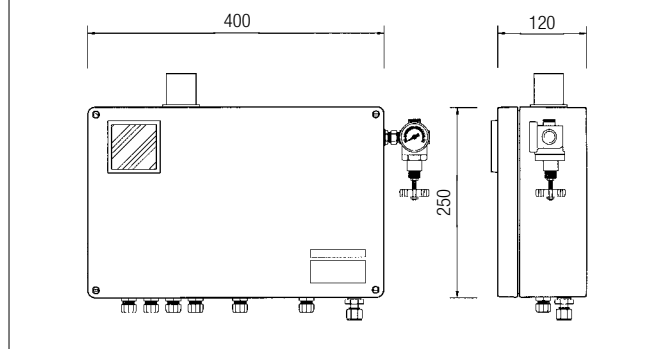

Ordering information

Version		Code no.
	230 V AC	1
	115 V AC	2

Complete order no. 07-3711-4213/ 001

Please insert code number.

Technical data subject to change without notice.



- Black box system
- Automatic calculation of the purge time
- Adjustable dynamic pressure feed
- Option to connect separate pressure sensors
- WEB interface
- 3 x PT100/1000 inputs
- Safety-related control system

SIL 2

Explosion protection

ATEX marking	Ⓜ II 2(1)G Ex eb mb ib [ib pxb] [ia Ga] IIC T4 Gb Ⓜ II 2(1)D Ex tb [ib pxb] [ia Da] IIIC T130 °C Db
Certification	BVS 19 ATEX E 015
IECEx marking	Ex eb mb ib [ib pxb] [ia Ga] IIC T4 Gb Ex tb [ib pxb] [ia Da] IIIC T130 °C Db
Certification	IECEx BVS 19.0038X
Other approvals and certificates, see www.bartec.com	
Ambient temperature	In storage -20 °C to +60 °C During operation -25 °C to +50 °C

Technical data

Directives	Directive 2014/30/EU Directive 2014/34/EU
Structure	Ex e protective housing with integrated Ex mb/ib-protected p control system
Housing material	V4A stainless steel
IP rating	IP 66 according to EN/IEC 60529 IP 64 according to EN/IEC 60079-0
Terminals	Ex e: 0.08 to 2.5 mm ² , fine-wire, tension spring Ex i: 0.2 to 1.5 mm ² , fine-wire, push-in
Pneumatic connections	2 x pipe connections, Ø 10 mm
Pressure measurement range	0 to 300 mbar
Adjustable differential pressure	Adjustable, 0 to 300 mbar
Orifice plate size	8 mm
Max. flow rate	6000 l/h
Pre-purge time	0 to 120 min
Weight	6.8 kg
Safety integrity level	SIL 2

The APEX^{dp} Ex p control unit controls and monitors the pre-purge and operating phase of pressurised enclosure equipment with integrated containment, which is protected in accordance with ignition protection type px, and additionally maintains the internal pressure of the protected equipment by Δp regulation during the operating phase. Connecting additional pressure sensors allows the pressure inside the housing to be regulated to a higher value than that of the measurement gas using a proportional valve. The parameters can be set using the integrated WEB interface or the optionally available p operator panel.

The APEX^{dp} features two release relays; one which is energised and one which has floating contacts. Two signal relays with one changeover contact each are additionally available. Three PT100/1000 inputs are available to monitor the temperature of the Ex p-protected equipment. Up to three switch values can be assigned to them. The design of the APEX^{dp} means that all components required for the pressurised enclosure are located in the control unit. The equipment to be monitored is connected to the Ex p control unit by means of a pipe, which allows a maximum purge volume of 70 litres. The following components can also be connected:

- There is the option to connect a p operator panel
- Pressure sensors

Electrical data

Supply voltage	24 V DC to 44 V DC, $\pm 10\%$ or 100 V AC to 230 V AC, $\pm 10\%$
Power consumption	Pv = approx. 19 watts
Normally open contacts	K1 (SIL) release, max. 5 A (AC1) K2 (SIL) release, floating, max. 230 V AC/3 A (AC1) K3 and K4 signal relays, floating, changeover contact, max. 1 A (AC1)
Inputs	3 x PT100/1000 1 x bypass 1 x main switch 1 x 4 – 20 mA [ib] – pressure sensor 1 x 4 – 20 mA [ia] – pressure sensor

Dimensions

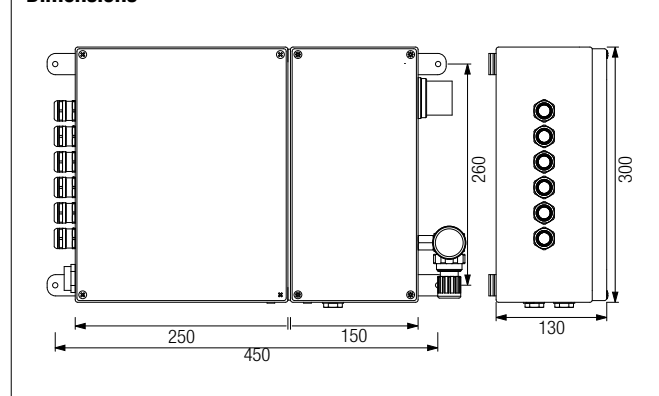

Ordering information

Version	Code no.
24 V DC to 44 V DC, $\pm 10\%$	1
100 V AC to 230 V AC, $\pm 10\%$	2

Complete order no. 07-37A2-2211/ 720

Please enter code number.

The accessories and order information can be found on the accessory pages. Technical data subject to change without notice.



- Four floating contacts
- Three-line LCD
- LED status indicator
- Modular design
- Safety-related control system
- Integrated multiport valves for purge gas inlet and outlet
- Option to connect separate pressure sensors

The APEX 2003.SI control unit controls and monitors the pre-purge and operating phase of Ex p-protected analysis systems with integrated containment.

Additional function:

Connecting additional pressure sensors allows the pressure inside the housing to be regulated to a higher value than that of the measurement gas using a proportional valve. During the pre-purge phase, the maximum purge gas flow rate is 4100 NL/h at a pressure of 50 mbar inside the housing. The control unit features two freely programmable relays and one non-floating release contact.

Explosion protection

ATEX marking	Ⓔ II 2(1)G Ex db eb ib [ia Ga] [pxb] IIC T4 Gb
Certification	DMT 99 ATEX E 082
Other approvals and certificates, see www.bartec.com	
Ambient temperature	-20 °C to +40 °C

Technical data

Directives	Directive 2014/30/EU Directive 2014/34/EU
Structure	Ex e protective housing with viewing pane in the cover
Housing material	Fibreglass-reinforced polyester
IP rating	IP 65
Terminals	2.5 mm ² , fine-wire
Purge gas connection	10 mm dia.
Pressure sensors	MIN. A/B = 0 to 300 mbar MAX. = 0 to 300 mbar DIFF. A/B = 0 to 25 mbar
Pre-purge time	0 to 99 min; 5 sec dropout delay
Weight	11 kg
Safety integrity level	SIL 2

Electrical data

Supply voltage	230 V AC (115 V AC) ±10 %
Power consumption	P _v = 21 W/230 V
Normally open contacts	K 2/3, 5 A when cos φ = 1 K 4 and K 5; floating
Temperature switch value (optional)	0 °C to +80 °C
Bypass key switch (optional)	

Dimensions

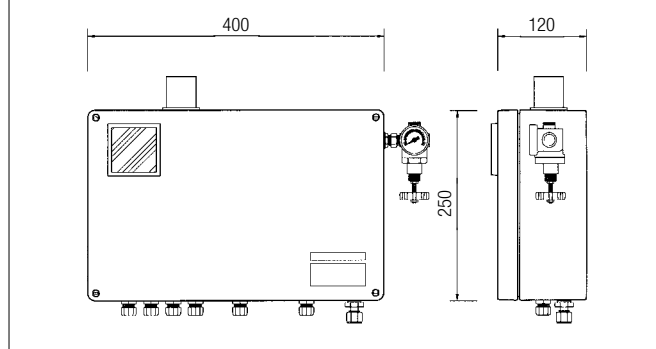

Ordering information

Version		Code no.
	230 V AC	1
	115 V AC	2

Complete oder no. 07-3711-3223/ 003

Please insert code number.

Technical data subject to change without notice.



- Black box system
- Automatic calculation of the purge time
- WEB interface
- 3 x PT100/1000 inputs
- Safety-related control system

SIL 2

Explosion protection

ATEX marking	Ⓜ II 2(1)G Ex eb mb ib [ib pxb] [ia Ga] IICT4 Gb Ⓜ II 2(1)D Ex tb [ib pxb] [ia Da] IIIC T130 °C Db
Certification	BVS 19 ATEX E 015
IECEx marking	Ex eb mb ib [ib pxb] [ia Ga] IIC T4 Gb Ex tb [ib pxb] [ia Da] IIIC T130 °C Db
Certification	IECEx BVS 19.0038X
Other approvals and certificates, see www.bartec.com	
Ambient temperature	In storage -20 °C to +60 °C During operation -25 °C to +50 °C

Technical data

Directives	Directive 2014/30/EU Directive 2014/34/EU
Structure	Ex e protective housing with integrated Ex mb/ib-protected p control system
Housing material	V4A stainless steel
IP rating	IP 66 according to EN/IEC 60529 IP 64 according to EN/IEC 60079-0
Terminals	Ex e: 0.08 to 2.5 mm ² , fine-wire, tension spring Ex i: 0.2 to 1.5 mm ² , fine-wire, push-in
Pneumatic connections	2 x pipe connections, 10 mm dia.
Pressure measurement range	0 to 25 mbar
Orifice plate size	8 mm
Max. flow rate	6000 l/h
Pre-purge time	0 to 120 min
Weight	6.8 kg
Safety integrity level	SIL 2

The APEX^{mv} Ex p control unit controls and monitors the pre-purge and operating phase of small, separate, pressurised enclosure equipment protected in accordance with ignition protection type px. The parameters can be set using the integrated WEB interface or the optionally available p operator panel.

The APEX^{mv} features two release relays; one which is energised and one which has floating contacts. Two signal relays with one changeover contact each are additionally available. Three PT100/1000 inputs are available to monitor the temperature of the Ex p-protected equipment. Up to three switch values can be assigned to them. The design of the APEX^{mv} means that all components required for the pressurised enclosure are located in the control unit. The equipment to be monitored is connected to the Ex p control unit by means of a pipe, which allows a maximum purge volume of 70 litres. The following components can also be connected:

- There is the option to connect a p operator panel
- Pressure sensors

Electrical data

Supply voltage	24 V DC to 44 V DC, ±10 % or 100 V AC to 230 V AC, ±10 %
Power consumption	Pv = approx. 19 watts
Normally open contacts	K1 (SIL) release, max. 5 A (AC1) K2 (SIL) release, floating, max. 230 V AC/3 A (AC1) K3 and K4 signal relays, floating, changeover contact, max. 1 A (AC1)
Inputs	3 x PT100/1000 1 x bypass 1 x main switch 1 x 4 to 20 mA [ib] – pressure sensor 1 x 4 to 20 mA [ia] – pressure sensor

Dimensions

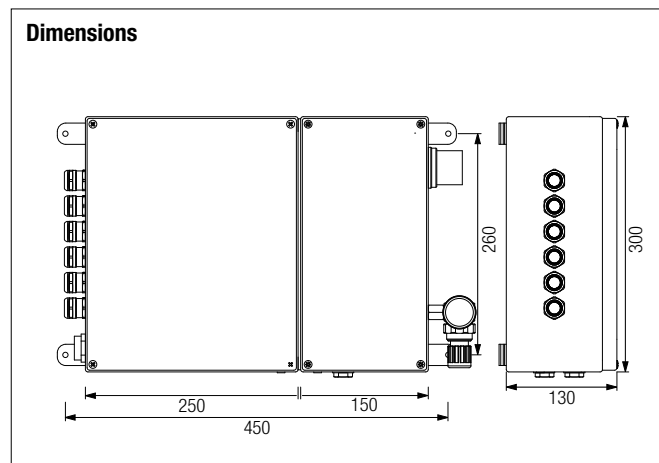

Ordering information

Version	Code no.
24 V DC to 44 V DC, ±10 %	1
100 V AC to 230 V AC, ±10 %	2

Complete order no. 07-37A2-2211/□730

Please enter code number.

The accessories and order information can be found on the accessory pages.

Technical data subject to change without notice.



- Four floating contacts
- Three-line LCD
- LED status indicator
- Safety-related control system
- Integrated multiport valve

The APEX 2003.MV control unit controls and monitors the pre-purge and operating phase of small, separate, pressurised enclosure housings with a maximum internal volume of 70 litres. The parameters are adjusted using rotary switches and keys. There is the option to transmit the parameters via an RS 485 interface. The control unit features two freely programmable relays and one non-floating release contact.

Explosion protection

ATEX marking	Ex II 2(1)G Ex db eb ib [ia Ga] [pxb] IIC T4 Gb
Certification	DMT 99 ATEX E 082
Other approvals and certificates, see www.bartec.com	
Ambient temperature	-20 °C to +40 °C

Technical data

Directives	Directive 2014/30/EU Directive 2014/34/EU
Structure	Ex e protective housing with viewing pane in the cover
Housing material	Fibreglass-reinforced polyester
IP rating	IP 65
Terminals	2.5 mm ² , fine-wire
Purge gas connection	10 mm dia.
Pressure sensors	MIN. A/B = 0 to 25 mbar MAX. = 0 to 25 mbar DIFF. A/B = 0 to 25 mbar
Pre-purge time	0 to 99 min; 5 sec dropout delay
Weight	5.9 kg
Safety integrity level	SIL 2

Electrical data

Supply voltage	230 V AC (115 V AC) ±10 %
Power consumption	P _v = 15 W/230 V
Normally open contacts	K 2/3, 5 A when cos φ = 1 K 4 and K 5; floating
Temperature switch value (optional)	0 °C to +80 °C
Bypass key switch (optional)	

Dimensions

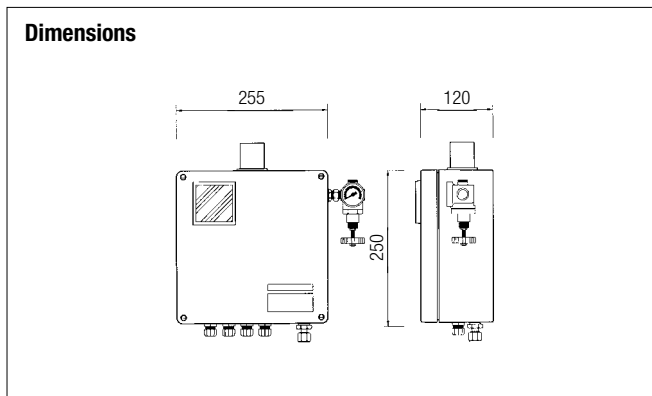

Ordering information

Version		Code no.
	230 V AC	1
	115 V AC	2

Complete order no. 07-3711-2213/ 000
 Please insert code number.
 Technical data subject to change without notice.



- Black box system
- Automatic calculation of the purge time
- WEB interface
- 3 x PT100/1000 inputs
- Modular design
- Separate purge gas input and output

Explosion protection

ATEX marking	Ⓜ II 3G Ex ec mc ic [ic pzc] IIC T5, T4 Gb Ⓜ II 3D Ex tc [ic pzc] IIIC T95°C, T130°C Db
Certification	BVS 19 ATEX E 016
IECEX marking	Ex ec mc ic [ic pzc] IIC T5, T4 Gb Ex tc [ic pzc] IIIC T95°C, T130°C Db
Certification	IECEX BVS 19.0038X
Other approvals and certificates, see www.bartec.com	
Ambient temperature	In storage -20 °C to +60 °C During operation -25 °C to +60 °C/T4 -25 °C to +50 °C/T5

Technical data

Directives	Directive 2014/30/EU Directive 2014/34/EU
Structure	Ex e protective housing with integrated Ex mc/ic-protected p control system
Housing material	V4A stainless steel
IP rating	IP 66 according to EN/IEC 60529 IP 64 according to EN/IEC 60079-0
Terminals	Ex e: 0.08 to 2.5 mm ² , fine-wire, tension spring Ex i: 0.2 to 1.5 mm ² , fine-wire, push-in
Pressure measurement range	0 to 25 mbar (standard) or 0 to 300 mbar (on request)
Pre-purge time	0 to 120 min
Weight	5.8 kg

The SILAS^{pz} Ex p control unit controls and monitors the pre-purge and operating phase of pressurised enclosure equipment protected in accordance with ignition protection type pz. Digital or proportional purge gas valves can be used as purge gas valves. The parameters can be set using the integrated WEB interface or the optionally available p operator panel. The SILAS^{pz} features two release relays; one which is energised and one which has floating contacts. Two signal relays with one changeover contact each are additionally available. Three PT100/1000 inputs are available to monitor the temperature of the Ex p-protected equipment. Up to three switch values can be assigned to them. Model I comes complete with separate pressure measurement. The following components are additionally required to set up a complete control system:

- Sensor box^{pz} 25 mbar
- Pressure monitor
- Purge gas valve, proportional or digital
- Valve fuse
- Pressure reducer
- There is the option to connect a p operator panel

Electrical data

Supply voltage	24 V DC to 44 V DC, ±10 % or 100 V AC to 230 V AC, ±10 %
Power consumption	P _v = approx. 19 watts
Normally open contacts	K1 release, max. 5 A (AC1) K2 release, floating, max. 230 V AC/3 A (AC1) K3 and K4 signal relays, floating, changeover contact, max. 1 A (AC1)
Inputs	3 x PT100/1000 1 x bypass 1 x main switch

Dimensions

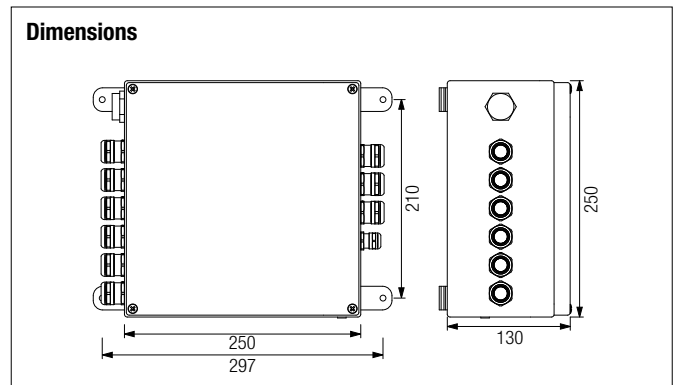

Ordering information

Version	Code no.
24 V DC to 44 V DC, ±10 %	1
100 V AC to 230 V AC, ±10 %	2

Complete order no. A7-37S2-2111/□ 510

Please enter code number.

The accessories and order information can be found on the accessory pages. Technical data subject to change without notice.



- Black box system
- Automatic calculation of the purge time
- WEB interface
- 3 x PT100/1000 inputs
- Modular design
- Separate purge gas input and output

Explosion protection

ATEX marking	Ⓜ II 3G Ex ec mc ic [ic pzc] IIC T4 Gb Ⓜ II 3D Ex tc [ic pzc] III C T130 °C Db
Certification	BVS 19 ATEX E 016
IECEx marking	Ex ec mc ic [ic pzc] IIC T4 Gb
Certification	Ex tc [ic pzc] III C T130 °C Db IECEx BVS 19.0038X
Other approvals and certificates, see www.bartec.com	
Ambient temperature	In storage -20 °C to +60 °C During operation -25 °C to +60 °C/T4 -25 °C to +50 °C/T5

Technical data

Directives	Directive 2014/30/EU Directive 2014/34/EU
Structure	Ex e protective housing with integrated Ex mc/ic-protected p control system
Housing material	V4A stainless steel
IP rating	IP 66 according to EN/IEC 60529 IP 64 according to EN/IEC 60079-0
Terminals	Ex e: 0.08 to 2.5 mm ² , fine-wire, tension spring Ex i: 0.2 to 1.5 mm ² , fine-wire, push-in
Pneumatic connections	2 x hoses, 4 mm dia.
Pressure measurement range	0 to 25 mbar (standard) or 0 to 300 mbar (on request)
Pre-purge time	0 to 120 min
Weight	5.8 kg

The SILAS^{pz} Ex p control unit controls and monitors the pre-purge and operating phase of pressurised enclosure equipment protected in accordance with ignition protection type pz. Digital or proportional purge gas valves can be used as purge gas valves. The parameters can be set using the integrated WEB interface or the optionally available p operator panel. The SILAS^{pz} features two release relays; one which is energised and one which has floating contacts. Two signal relays with one changeover contact each are additionally available. Three PT100/1000 inputs are available to monitor the temperature of the Ex p-protected equipment. Up to three switch values can be assigned to them. Model II comes complete with integrated pressure measurement. The following components are additionally required to set up a complete control system:

- Pressure monitor
- Purge gas valve, proportional or digital
- Valve fuse
- Pressure reducer
- There is the option to connect a p operator panel

Electrical data

Supply voltage	24 V DC to 44 V DC, ±10 % or 100 V AC to 230 V AC, ±10 %
Power consumption	Pv = approx. 19 watts
Normally open contacts	K1 release, max. 5 A (AC1) K2 release, floating, max. 230 V AC/3 A (AC1) K3 and K4 signal relays, floating, changeover contact, max. 1 A (AC1)
Inputs	3 x PT100/1000 1 x bypass 1 x main switch

Dimensions

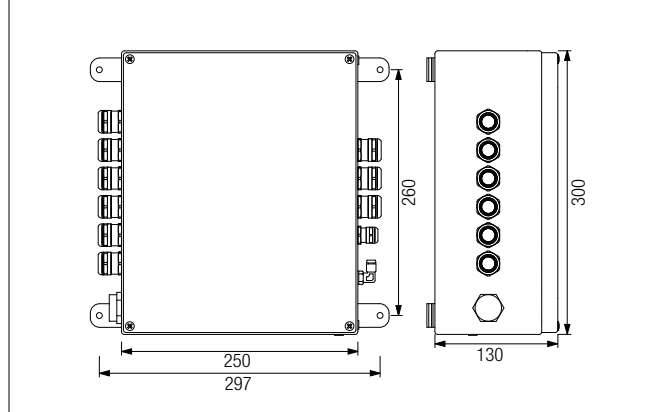

Ordering information

	Code no.
24 V DC to 44 V DC, ±10 %	1
100 V AC to 230 V AC, ±10 %	2

Complete order no. A7-37S2-2111/ 520

Please insert code number.

The accessories and order information can be found on the accessory pages. Technical data subject to change without notice.



- Small design
- Easy to use
- Separate purge gas input and output

The SILAS control system is used to monitor electrical equipment constructed in accordance with the method of "pressurised enclosure with leakage loss compensation". Consisting of a SILAS control unit type A7-3741-1110/*000 and a pressure monitor type 17-51P3-1604, this is a complete safety device. The following components are additionally required to set up a complete control system:

- Pressure monitor
- Purge gas valve, digital (gas application)
- Pressure reducer

Explosion protection

Marking/ambient temperature	
ATEX marking	Ⓢ II 3G Ex nA nC [pzc] IIC T4 Gc Ⓢ II 3G Ex nA nC [pzc] IIC T6 Gc Ⓢ III 3D Ex tc [pzc] IIIB T85 °C Dc
Certification	TÜV 09 ATEX 553359 X
IECEX marking	Ex nA nC [pzc] IIC T4 Gc Ex nA nC [pzc] IIC T6 Gc Ex tc [pzc] IIIB T85 °C Dc
Certification	IECEX TUN 10.0030 X
Other approvals and certificates, see www.bartec.com	
Approved for	Zone 2 and Zone 22
Ambient temperature	In storage -20 °C to +60 °C During operation -20 °C to +60 °C/T4 -20 °C to +40 °C/T6

Technical data

Directives	Directive 2014/30/EU Directive 2014/34/EU
Structure	Protective housing with or without viewing pane
Housing material	Polyester, fibreglass-reinforced
IP rating	IP 54
Terminals	0.08 to 2.5 mm ² , fine-wire, tension spring
Pressure measurement range	0 to 25 mbar (standard)
Pre-purge time	0 to 60 min
Weight	1.2 kg

Electrical data

Supply voltage	24 V DC, ±10 % 115 V AC, ±10 % 230 V AC, ±10 %
Power consumption	8 watts
Normally open contacts	Release relay, floating Alarm relay, floating Control relay Purge valve

Dimensions

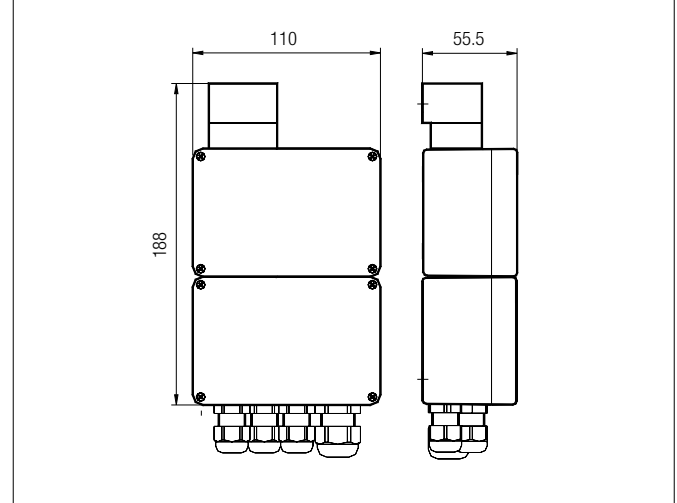

Ordering information

Supply voltage	Code no.	Version	Code no.
230 V AC, ±10 %, 50 Hz – 60 Hz	1	Without viewing pane	0
115 V AC, ±10 %, 50 Hz – 60 Hz	2	With viewing pane	2
24 V DC, ±10 %	4		

Complete oder no. A7-3741-1110/ 00
 Please insert code number.
 Technical data subject to change without notice.



- Black box system
- Automatic calculation of the purge time
- WEB interface
- 3 x PT100/1000 inputs

The SILAS^{mv} Ex p control unit controls and monitors the pre-purge and operating phase of small, separate, pressurised enclosure equipment protected in accordance with ignition protection type pz. The parameters can be set using the integrated WEB interface or the optionally available p operator panel. The SILAS^{mv} features two release relays; one which is energised and one which has floating contacts. Two signal relays with one changeover contact each are additionally available. Three PT100/1000 inputs are available to monitor the temperature of the Ex p-protected equipment. Up to three switch values can be assigned to them. The design of the SILAS^{mv} means that all components required for the pressurised enclosure are located in the control unit. The equipment to be monitored is connected to the Ex p control unit by means of a pipe, which allows a maximum purge volume of 70 litres. The following components can also be connected:

- There is the option to connect a p operator panel

Explosion protection

ATEX marking	Ⓜ II 3G Ex ec mc ic [ic pzc] IIC T4 Gb Ⓜ II 3D Ex tc [ic pzc] III C T130 °C Db
Certification	BVS 19 ATEX E 016
IECEx marking	Ex ec mc ic [ic pzc] IIC T4 Gb Ex tc [ic pzc] III C T130 °C Db
Certification	IECEx BVS 19.0038X Other approvals and certificates, see www.bartec.com
Ambient temperature	In storage -20 °C to +60 °C During operation -25 °C to +50 °C

Technical data

Directives	Directive 2014/30/EU Directive 2014/34/EU
Structure	Ex e protective housing with integrated Ex mc/ic-protected p control system
Housing material	V4A stainless steel
IP rating	IP 66 according to EN/IEC 60529 IP 64 according to EN/IEC 60079-0
Terminals	Ex e: 0.08 to 2.5 mm ² , fine-wire, tension spring Ex i: 0.2 to 1.5 mm ² , fine-wire, push-in
Pneumatic connections	2 x pipe connections, 10 mm dia.
Pressure measurement range	0 to 25 mbar
Orifice plate size	8 mm
Max. flow rate	6000 l/h
Pre-purge time	0 to 120 min
Weight	6.8 kg

Electrical data

Supply voltage	24 V DC to 44 V DC, ±10 % or 100 V AC to 230 V AC, ±10 %
Power consumption	Pv = approx. 19 watts
Normally open contacts	K1 release, max. 5 A (AC1) K2 release, floating, max. 230 V AC/3 A (AC1) K3 and K4 signal relays, floating, changeover contact, max. 1 A (AC1)
Inputs	3 x PT100/1000 1 x bypass 1 x main switch

Dimensions

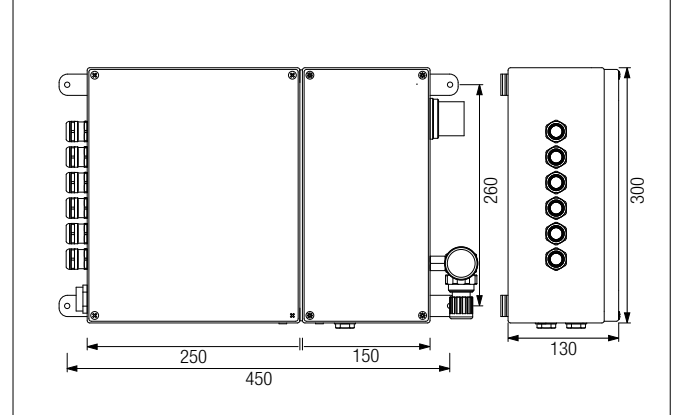

Ordering information

	Code no.
24 V DC to 44 V DC, ±10 %	1
100 V AC to 230 V AC, ±10 %	2

Complete order no. A7-37S2-2111/ 730

Please insert code number.

The accessories and order information can be found on the accessory pages. Technical data subject to change without notice.



- Black box system
- Automatic calculation of the purge time
- WEB interface
- 3 x PT100/1000 inputs

The SILAS^{mpc} Ex p control unit controls and monitors the pre-purge and operating phase of pressurised enclosure motors protected in accordance with ignition protection type px. The parameters can be set using the integrated WEB interface or the optionally available p operator panel. The SILAS^{mpc} features two release relays; one which is energised and one which has floating contacts. Two signal relays with one changeover contact each are additionally available. Three PT100/1000 inputs are available to monitor the temperature of the Ex p-protected equipment. Up to three switch values can be assigned to them. All the components required to set up Ex px monitoring and the purge gas valve are integrated in the SILAS^{mpc}. The following components are additionally required to set up a complete control system:

- "Motor purge valve MPC" outlet
- There is the option to connect a p operator panel

Explosion protection

ATEX marking	⊕ II 3 G Ex ec mc ic [ic pzc] IIC T4 Gb
Certification	⊕ II 3 D Ex tc [ic pzc] IIIC T130 °C Db BVS 19 ATEX E 016
IECEx marking	Ex ec mc ic [ic pzc] IIC T4 Gb
Certification	Ex tc [ic pzc] IIIC T130 °C Db IECEx BVS 19.0038X
Other approvals and certificates, see www.bartec.com	
Ambient temperature	In storage -20 °C to +60 °C During operation -25 °C to +50 °C -50 °C to +50 °C (HT) 230 V AC or 110 V AC heating is available on the HT version. Please state which voltage you require when ordering.

Technical data

Directives	Directive 2014/30/EU Directive 2014/34/EU
Structure	Ex e protective housing with integrated Ex mb/ib-protected p control system
Housing material	V4A stainless steel
IP rating	IP 66 according to EN/IEC 60529 IP 64 according to EN/IEC 60079-0
Terminals	Ex e: 0.08 to 2.5 mm ² , fine-wire, tension spring Ex i: 0.2 to 1.5 mm ² , fine-wire, push-in
Pneumatic connections	Purge gas supply in: G 1 ½", internal thread G Purge gas supply out: 1 ½", external thread MPV activation: Pipe connection 10 mm Pressure measurement: 2 x pipe connections 10 mm
Pressure measurement range	0 to 25 mbar (standard) or 0 to 300 mbar (on request)
Pre-purge time	0 to 120 min
Flow rate	Leakage compensation Mechanical, up to 11.5 l/sec Purge gas volume Digital, 0 to 450 m ³ /hour
Weight	40 kg

Electrical data

Supply voltage	24 V DC to 44 V DC, ±10 % or 100 V AC to 230 V AC, ±10 %
Power consumption	Pv = approx. 19 watts
Normally open contacts	K1 release, max. 5 A (AC1) K2 release, floating, max. 230 V AC/3 A (AC1) K3 and K4 signal relays, floating, changeover contact, max. 1 A (AC1)
Inputs	3 x PT100/1000 1 x bypass 1 x main switch

Dimensions

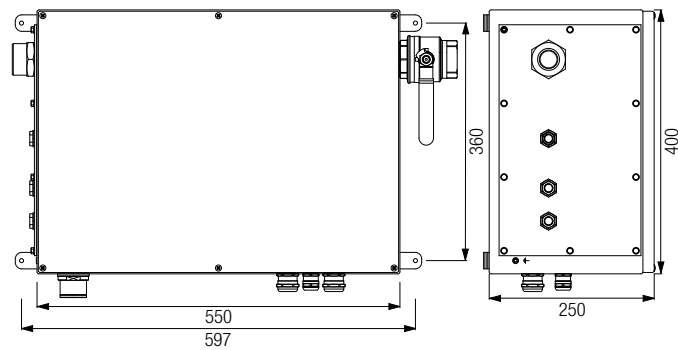

Ordering information

Controller supply voltage	Code no.	Temperature range, UV heating	Code no.
24 V DC to 44 V DC, ±10 %	1	-25 °C to +50 °C	0
		-50 °C to +50 °C, 230 V AC	1
100 V AC to 230 V AC, ±10 %	2	-50 °C to +50 °C, 110 V AC	2

Complete order no. Zones 1, 21 07-37A2-2211/ M5

 Zones 2, 22 A7-37S2-2111/ M5

Please insert code number.

The accessories and order information can be found on the accessory pages.

We reserve the right to make technical changes.



- Mounting position independently

The motor purge control system consisting of an MPC Motor Purge Controller and an MPV Motor Purge Valve (outlet valve) is a unit which allows the safe operation of electric motors in hazardous environments. The explosion protection is ensured by means of a pressurised enclosure with leakage loss compensation. The Motor Purge Control System monitors, controls and regulates the supply of purge gas to the Ex p motor. Any faults that arise within the system or during the supply of purge gas will be reliably reported and deactivated by a safe disconnection of the Ex p motor.

Technical Data

Construction	valve-controlled outlet for MPC
Varnish	RAL 7035
Enclosure material	Sheet steel (stainless steel on request)
Protection class	IP 65
Pressure relief	integrated, opens at 50 mbar
Connections	2 x pipe connection 10 mm
Mounting	horizontal or vertical
Flying spark and particle barrier	integrated
Flow rate	0 to 180 m ³ /h at MPV 2 with MPC 2 0 to 450 m ³ /h at MPV 3 with MPC 3
Connection flange	DIN2633 NW 50 PN16 (MPV 2) DIN2633 NW 100 PN16 (MPV 3) (Dimensions and details see Operating Instructions)
Ambient temperature	-30 °C to +60 °C

Dimensions

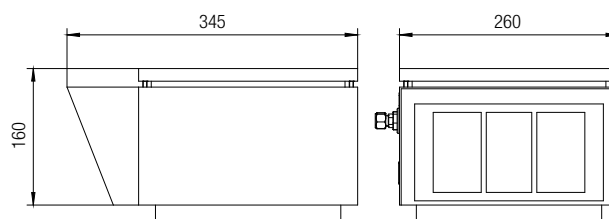

Ordering information

Description	Variant	Code no.
System MPC	MPV 2	8
	MPV 3	9

Complete order no. 17-51P3-3 03

Please enter code number.

Technical data subject to change without notice.



- Optional expansion p control system
- Plain text display
- Visual pressure information via LED
- Menu operation
- Status screens
- Three versions: Front panel mounting, front panel installation, or mobile use

Explosion protection

ATEX marking	II 2G Ex ib IIC T4 Gb
Certification	BVS 19 ATEX E 017X
IECEx marking	Ex ib IIC T4 Gb
Certification	IECEx BVS 19.0038X
Other approvals and certificates, see www.bartec.com	
Ambient temperature	In storage -25 °C to +60 °C During operation -20 °C to +50 °C

Version I – Mobile unit

Connection	Plug connector, 2m cable One matching part for control unit included in the delivery
Weight	Approx. 2.5 kg (depending on the version)

Version II – Front panel mounting

Connection	4 x 0.5 mm ² , 2 m cable Fixed connection on the control unit
Weight	Approx. 2.5 kg (depending on the version)

Version III – Front panel installation

Connection	4 x 0.5 mm ² , 2 m cable Fixed connection on the control unit
Weight	Approx. 2.5 kg (depending on the version)

The p Operator panel is designed for optional use with the new generation of Ex p control systems. It displays and visualises system-specific pressures, and displays parameters, plain text messages and system statuses. The p operator panel can be directly connected to the Ex p control unit, which supplies it with the required intrinsically safe voltage. Three versions of the p operator panel are available:

Version I – Mobile unit

The mobile unit is equipped with an Ex-protected plug connector. When using multiple Ex p control units, in order to carry out maintenance, the mobile unit can be connected to the Ex p control unit and removed again once the work is complete. The flanged socket required is securely installed on the control unit and is enclosed when the shipment is first ordered.

Version II – Front panel mounting

The front panel mounting version is secured to doors or adjacent walls, for example, using the mounting brackets fitted to the protective housing. The connection between the p operator panel and Ex p control system can be 2 m long.

Version III – Front panel installation

The front panel installation version has no protective housing and can be installed directly in the door of the p-protected equipment, for example.

Technical specifications

Directives	Directive 2014/30/EU Directive 2014/34/EU
Housing material	V4A stainless steel (variant)
IP rating	IP 65 according to EN/IEC 60529

Electrical data

Supply voltage	3.3 V DC (internal)
Power consumption	P _v = approx. 2 watts

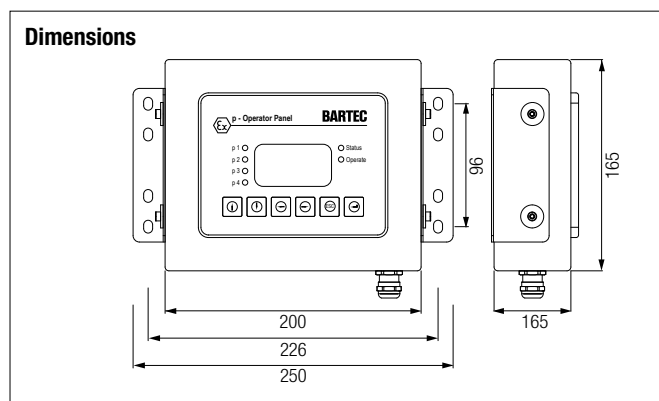

Ordering information

	Code no.
Version I – Mobile unit	0
Version II – Surface-mounted	1
Version III – Installed version	2

Complete order no. 17-51P5- 111

Please insert code number.

The accessories and order information can be found on the accessory pages. Technical data subject to change without notice.



The sensor box is for APEX px/py or SILAS^{pz} Ex p control units, model I. This contains the measuring card to measure the pressures inside the Ex p equipment and to convert them into an electrical signal. The maximum length between the Ex p control unit and the sensor box is 2 m.

Explosion protection

Zone 1	
ATEX marking	Ⓜ II 2G Ex ib IIC T4/T5 Gb Ⓜ II 2D Ex ib IIIC T95 °C, T130 °C Db
Certification	BVS 19 ATEX E 015
IECEX marking	Ex ib IIC T4/T5 Gb Ex ib IIIC T95 °C, T130 °C Db
Certification	IECEX BVS 19.0038X
Zone 2	
ATEX marking	Ⓜ II 3G Ex ic IIC T4/T5 Gb Ⓜ II 3D Ex ic IIIC T95 °C, T130 °C Dc
Test certificate	BVS 19 ATEX E 016
IECEX marking	Ex ic IIC T4/T5 Gc Ex ic IIIC T95 °C, T130 °C Dc
Test certificate	IECEX BVS 19.0038X
Other approvals and certificates, see www.bartec.com	
Ambient temperature	In storage -20 °C to +60 °C During operation -25 °C to +60 °C

Technical data

Directives	Directive 2014/30/EU Directive 2014/34/EU
Housing material	V4A stainless steel (variant)
IP rating	IP 66 according to EN/IEC 60529

Electrical data

Supply voltage	3.3 V DC (internal)
Power consumption	Pv = approx. 2 watts
Terminals	Ex i: 0.2 to 1.5 mm ² , fine-wire, screw terminal

Pneumatic data

Pneumatic connections	2 x hoses 4 mm
Pressure measurement range	0 to 25 mbar (standard) or 0 to 300 mbar (on request)

Versions

SENSOR BOX ^{px}	For APEX ^{px} Ex px control system, model I
SENSOR BOX ^{py}	For APEX ^{py} Ex py control system, model I
SENSOR BOX ^{pz}	For SILAS ^{pz} Ex pz control system, model I

Dimensions

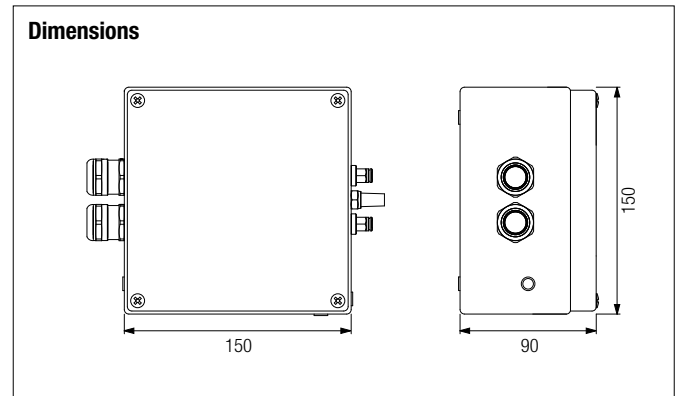

Ordering information

Version	Order number
SENSOR BOX ^{px}	05-0070-1077
SENSOR BOX ^{py}	05-0070-1078
SENSOR BOX ^{pz}	05-0070-1079

Technical data subject to change without notice.



- Easy to install
- Easy to use

The sensor module is designed to be used in APEX control systems. It measures the system-specific pressures and displays parameters and pressure values. The sensor module is directly connected to the APEX control unit, which supplies it with the required intrinsically safe voltage. Measured signals are forwarded to the APEX control module in an intrinsically safe manner. The sensor module is connected by single conductors or a hose line, depending on the version.

Explosion protection

ATEX marking	II 2G Ex ib IIC T4 Gb
Certification	DMT 99 ATEX E 108 X
IECEX marking	Ex ib IIC T4 Gb
Certification	IECEX BVS 09.0055X
Other approvals and certificates, see www.bartec.com	
Approved for	Zones 1 and 2

Technical data

Directives	Directive 2014/30/EU Directive 2014/34/EU
Mounting	Screw attachment on mounting plate, front mounting with mounting frame
Housing materials	Plastic housing with metal front panel
IP rating	Min. IP 20
Displays	LCD in the front of the housing
Controls	Membrane push-buttons
Weight	1.0 kg
Ambient temperature	In storage -20 °C to +60 °C During operation -20 °C to +60 °C

Electrical data

Power consumption $P_V = 1.2 \text{ W}$		
Ex i circuits	Supply circuit	$U_i = 30 \text{ V}$ $C_i = 50 \text{ nF}$ $L_i = \text{negligible}$
	LCD supply circuit	$U_i = -7.5 \text{ V}$ $I_i = 10 \text{ mA}$ $P_i = 20 \text{ mW}$ $C_i = \text{negligible}$ $L_i = \text{negligible}$
	Signal current circuits	$U_i = 7.5 \text{ V}$ $C_i = 1 \mu\text{F}$ $L_i = \text{negligible}$
Interconnected supply circuits and signal current circuits Maximum total current = 250 mA Maximum total power = 1.2 W		

Ordering information

T4 sensor module	Version	Code no.	Pressure range	Code no.
	Installation	1	0 to 25 mbar	1
	Mounting	2	0 to 300 mbar	2

Complete order no. 17-51P2--00
Please insert code number.

T6 available on request.
Technical data subject to change without notice.



The pressure monitor module forms part of pressurised enclosure control systems. Various versions are available for applications in Zones 1, 21 and 2, 22.

Function of pressure monitor module for Zones 1, 21

- Overpressure monitor
- Taps for flow rate measurement

Function of pressure monitor module for Zones 2, 22

- Overpressure monitor
- Flow valve

Dimensions Zone 1 version

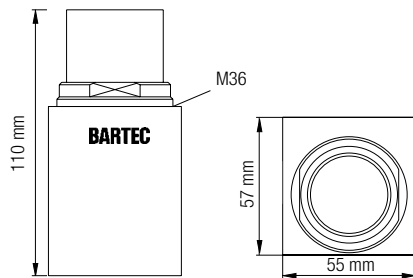

Pressure monitor module for Zones 1, 21

Technical data

Temperature range	-20 °C to +80 °C
Installation	In Ex px/py equipment
Mounting hole	Ø 37 mm
Connection	Quick connector for hose
Flying spark barrier	x 3
Installation position	Plastic body inside Ex p equipment
Opening pressure	3 mbar
IP rating	IP 65

Dimensions Zone 2 version

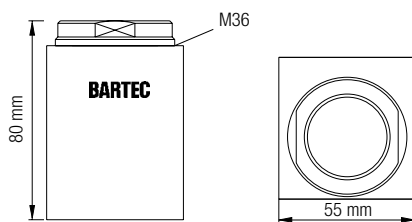

Pressure monitor module for Zones 2, 22

Technical data





Temperature range	-25 °C to +80 °C
Installation	In Ex pz equipment
Mounting hole	Ø 37 mm
Flying spark barrier	x 2
Installation position	Plastic body inside Ex p equipment
Opening pressure	3 mbar
IP rating	IP 54

Ordering information

Version		Order number
Zone 1 module	Orifice plate, 5 mm	17-51P3-1203
	Orifice plate, 8 mm	17-51P3-1303
	Orifice plate, 12 mm	17-51P3-1403
	Orifice plate, 15 mm	17-51P3-1503
	Orifice plate, 18 mm	17-51P3-1603
Zone 2 or 22 module		17-51P3-1604







The accessories and order information can be found on the accessory pages. Technical data subject to change without notice.

Ordering information

Figure	Description	Order number
	<p>Purge gas valve with integrated leakage air compensation Ex Zone 1, Ex px/py control systems ATEX IECEx Operating principle: Open/closed; 2/2-way; closed in the idle position Nominal size: 13 mm Material: Brass Line connection: G3/8 bushing Power consumption: 9 watts Cable length: 3 m Items supplied: Valve, 2 x purge air nozzles with no holes</p> <p>Types 230 V AC 110 V AC 24 V DC</p>	<p>05-0056-0071 05-0056-0072 05-0056-0073</p>
	<p>Purge gas valve – Proportional Ex Zone 1, Ex px/py control systems ATEX IECEx Operating principle: Proportional; 2/2-way; closed in the idle position Nominal size: 6 mm Material: Brass Line connection: G3/8 bushing Power consumption: 15 watts Cable length: 3 m Items supplied: Valve, 2 x purge air nozzles with no holes</p> <p>Types 230 V AC 110 V AC 24 V DC</p>	<p>05-0056-0077 05-0056-0078 05-0056-0081</p>
	<p>Purge gas valve with integrated leakage air compensation Ex Zone 2, Ex pz control systems ATEX Operating principle: Open/closed; 2/2-way; closed in the idle position Nominal size: 13 mm Material: Brass Line connection: G3/8 bushing Power consumption: 9 watts Cable length: 3 m Items supplied: Valve, 2 x purge air nozzles with no holes</p> <p>Types 230 V AC 110 V AC 24 V DC</p>	<p>03-5110-0081 03-5110-0082 03-5110-0083</p>
	<p>Valve fuse Back-up fuse for purge gas valves</p> <p>1.0 A for digital purge gas valve 1.6 A for proportional purge gas valve</p>	<p>05-0080-1016 05-0080-1017</p>

Technical data subject to change without notice.

Ordering information

Figure	Description	Order number
	<p>Pressure reducer Controls: Handwheel with locking mechanism Any installation position is possible Pressure regulation range: 0.5 to 6 bar</p> <p>Items supplied: Pressure reducer with installation material</p>	
	<p>G ¼" pressure reducer Max. inlet pressure: 16 bar Connection: G ¼"</p>	05-0056-0083
	<p>G ½" pressure reducer Max. inlet pressure: 25 bar Connection: G ½"</p>	05-0056-0084
	<p>Pressure maintenance valve Zones 21, 22 With installation material for pressure reducer</p>	05-0056-0062 05-0056-0007
	<p>Programming switch For the new generation of APEX/SILAS</p>	05-0003-0089
	<p>Programming jumper for APEX 2003</p>	05-0012-0193
	<p>Rain/dust cap The rain/dust cap for the pressure monitor output protects against rain or dust deposits. This can be used as an optional accessory for pressure monitors with an internal orifice plate of up to 15 mm.</p>	05-0032-0011
	<p>Programming cable For APEX/SILAS new generation</p>	03-9828-0026

Technical data subject to change without notice.



APC APEX pressurised cabinet for Zone 1
SPC SILAS pressurised cabinet for Zone 2 or 22

The need for complex automation functions for processes in the chemical, pharmaceutical, oil and gas sectors is constantly increasing.

Flexible, reliable and low-maintenance solutions are required for measurement, control, regulation and visualisation, especially in potentially explosive atmospheres.

Complete control systems and switchgears, drives, pumps, large displays and industrial monitors, including keyboard and printer, must be prepared for use in Ex areas.

The Ex p pressurised enclosure is one of the most flexible Ex solutions for many applications.

This type of ignition protection makes it possible to operate non-ex-capable devices in potentially explosive atmospheres in Zones 1/21, 2/22. The idea behind this is to prevent a potentially explosive atmosphere from entering a sealed protective housing by generating constant overpressure compared to the surrounding atmosphere.

BARTEC offers a completely new Ex solution for controlling and automating devices, machines and systems in Zones 1/21, 2/22 in the form of the pressurised enclosure Ex p systems.

Depending on the application, non-Ex-protected control units and switching devices, as well as complete automation systems, are installed in the housing. Modern, ready-for-operation Ex solutions – including the required ATEX or IECEx certification – are created on the basis of BARTEC's modular, ATEX-certified pressurised enclosure. The overpressure as a result of the purge gas is produced by compensating for the leakage losses. The pressurised enclosure solution is designed for a large range of ambient temperatures in temperature classes T3 to T5.

The main focus is on maintenance and availability of Ex devices and systems. The experts at BARTEC have many years of experience in explosion protection applications and in designing complete systematic solutions for automation.

This expertise is the basis for developing reliable and efficient solutions, from engineering, manufacturing and procurement, through to commissioning and approval.

The Ex p solutions are designed from sheet steel or stainless steel, with air conditioning, with different coatings, seawater-resistant or drip-resistant, depending on the application.

Custom solutions

BARTEC offers custom pressurised enclosure solutions for

- Devices
- Printers
- Operating terminals
- Control systems
- Frequency converters
- Monitors

Air conditioning

BARTEC can also provide you with various solutions for the air conditioning of Ex p systems on request

- Heating during operation
- Heating when stationary
- Air cooler
- Air conditioning

Accessories

- Purge gas filter systems
- Release contactor
- Isolating relay for data lines
- Bypass key switch



Explosion protection

APC marking

ATEX	Ⓜ II 2G Ex px IIC T3 to T6 Gb Ⓜ II 2G Ex px ib IIC T3 to T6 Gb
Certification	BVS 11 ATEX E 144
IECEX	Ex px IIC T3 to T6 Gb Ex px ib IIC T3 to T6 Gb
Certification	IECEX BVS 13.0049
Other approvals and certificates, see www.bartec.com	

SPC marking

ATEX	Ⓜ II 3G Ex pz IIC T3 to T6 Gc Ⓜ II 3G Ex pz ib IIC T3 to T6 Gc
Test certificate	BVS 11 ATEX E 145
IECEX	Ex pz IIC T3 to T6 Gc Ex pz ib IIC T3 to T6 Gc
Test certificate	IECEX BVS 11.0070
Other approvals and certificates, see www.bartec.com	

Technical data

Directives	Directive 2014/30/EU Directive 2014/34/EU
Structure	Standard housing or custom solution
Housing material	Stainless steel, sheet steel
Ambient temperature	-20 °C to +60 °C (application-dependent)
IP rating	Application-dependent, at least IP 54
Housing volume	Up to 6336 litres
Purge gas	Purified compressed air or inert gas, Tmax = +40 °C
Purge gas inlet pressure	3 to 25 bar
Operating pressure	Version-dependent, between 2 and 4 mbar
Purge pressure	Version-dependent, between 1 and 20 mbar
Pre-purge time	Application-dependent

Electrical data

Supply voltage	Max. 690 V AC
Power consumption	Application-dependent

We would be happy to provide a pressurised enclosure solution on request.

Please use the specification sheet below for your request.
 Technical data subject to change without notice.

Customer request Specification sheet request for Ex p

Customer

BARTEC (to be completed by BARTEC employee)

Company	Sales employee
Street	Project name
Town/postcode	Request number
Country	Deadlines
Contact	Submission of quote
E-mail	Telephone

Documents provided

<input type="checkbox"/> Wiring diagrams	<input type="checkbox"/> Parts list
<input type="checkbox"/> Drawings	<input type="checkbox"/> Data sheets
<input type="checkbox"/> Other	

Area of application

<input type="checkbox"/> Zone 1 (2G)	<input type="checkbox"/> Outdoors
<input type="checkbox"/> Zone 2 (3G)	<input type="checkbox"/> Indoors
<input type="checkbox"/> Zone 21 (2D)	<input type="checkbox"/> Cleanroom
<input type="checkbox"/> Zone 22 (3D)	<input type="checkbox"/> Other:
<input type="checkbox"/> ATEX-certified	<input type="checkbox"/> IECEx-certified
<input type="checkbox"/> Explosion group:	
<input type="checkbox"/> Temperature class	<input type="checkbox"/> T4 <input type="checkbox"/> T6

Operating voltage

<input type="checkbox"/> 400 V AC	<input type="checkbox"/> 24 V DC
<input type="checkbox"/> 230 V AC	<input type="checkbox"/> Power consumption:
<input type="checkbox"/> 115 V AC	<input type="checkbox"/> Other:

Material and "pressurised cabinet" design

Housing size (mm): Width	x Height	x Depth
<input type="checkbox"/> V2A stainless steel (1.4301, AISI 304)		
<input type="checkbox"/> V4A stainless steel V4A (1.4401, AISI 316L)		
<input type="checkbox"/> Sheet steel, coating according to RAL:		
<input type="checkbox"/> Single-door		
<input type="checkbox"/> Two-door		
<input type="checkbox"/> Multi-door		

Temperatures

Internal power loss	W
Max. outdoor temperature	°C
Min. outdoor temperature	°C
Max. indoor temperature	°C
Min. indoor temperature	°C

Activation

<input type="checkbox"/> Direct activation via control unit, max. L/N, 5 A
<input type="checkbox"/> Indirect activation via Ex d contactor
<input type="checkbox"/> Activation from non-Ex zone
<input type="checkbox"/> Manual activation, for Zone 2 only

<input type="checkbox"/> Base, height:	mm
<input type="checkbox"/> Sun canopy	
<input type="checkbox"/> Lifting brackets	
<input type="checkbox"/> Viewing pane, size	W mm
	H mm
<input type="checkbox"/> Mounting plate provided	
<input type="checkbox"/> Wiring by BARTEC MGH	

Customer request Specification sheet request for Ex p

Interfaces used

Two-wire

PROFIBUS

Ethernet

Four-wire

PROFINET

Other:

Controls

HMI, Type:

x push-button(s)

Contact type:

x indicator light, colour:

x illuminated push-button(s)

Contact type, colour:

x key switch

Contact type:

x selector switch(s)

Contact type:

x Emergency stop

Contact type:

Cable glands

Quantity

Size

Ex i

Quantity

Size

Ex i
