

Hazardous Area Monitor Systems

Class 1, Zone 1 Fire Fighting Monitors



orion
High Performance Fire Protection



Orion Fire Engineering is an engineering company based in Sydney, Australia, which specialises in the design and manufacture of fire fighting equipment, predominantly for the oil and gas industry. Established in 1985, the company has developed into a market-leader in the fire industry, and has supplied products to protect major assets all over the world.

The Orion Hazardous Area Monitor System is a highly effective fire monitor system for use in a variety of applications such as jetties, refineries, chemical plants and helidecks. They can be used for water/foam application, cooling water and vapour suppression. The system is designed and built in our facility in Sydney, Australia, and can be configured to suit almost any user requirements.

System Arrangement

Our monitor system is designed so that each monitor is a completely self-contained system with a wide variety of optional equipment. Communications within the system can use RS485, fibre-optic, wireless networking or a mixture. A central computer can supervise multiple monitors and display monitor status and position.

Why Choose an Orion Monitor?

Australian Designed and Manufactured with 30 Years Experience in the Fire Fighting Industry

Our products are designed and manufactured in our facility in Sydney, Australia.

We have been manufacturing products for the fire fighting industry for over 30 years, which gives us product and application knowledge which is second to none.

Hazardous Area Certified (ATEX and IECEx Exd Class 1, Zone 1)

The system has been specifically designed to be used in hazardous areas.

Corrosion Resistance

In many applications it is corrosion that compromises the life of the equipment. Our monitors are designed so that there are no components exposed to the environment which could be subject to corrosion, improving product reliability and reducing system down time.

Robust and Fault Tolerant

Our equipment is designed and manufactured to ensure it can cope with unexpected events.

Flexible Control Options

A number of controllers can be connected to allow a single monitor to be controlled from a variety of locations, as well as being configured to control more than just the monitor.

Easy Installation

With only power and a communication cable required to connect each device, installation times are minimised.

Easy Commissioning

The system can easily be configured from a laptop, resulting in shorter commissioning times.

High Performance

The most efficient monitors and nozzles on the market give excellent and proven performance characteristics which are the envy of all of our competitors.

Low Cost of Ownership

With exemplary product development, the monitors have very little maintenance requirements, and therefore very high levels of system up time, allowing for years of trouble-free product use.

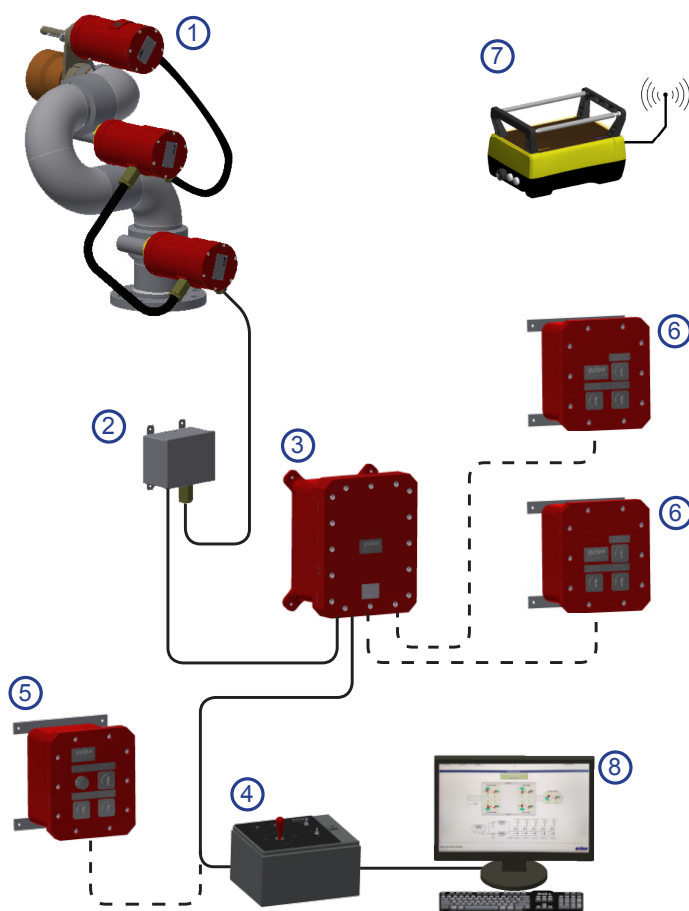

System Items Explained

- 1) Orion Hazardous Area monitor and nozzle.
- 2) Exe junction box (pre-wired to monitor by Orion)
- 3) Power Supply Module (PSM), containing power supply and terminations from field
- 4) Master Control Station (IP66) designed to control 1 or a number of monitors from a safe area (non-EXd).
- 5) Master Control Station (EXd), as per the IP66 version, but Exd rated.
- 6) Local Control Station (EXd). Field mounted control stations to allow control from more than 1 location.
- 7) Radio Remote Control Station. Exd rated radio remote controller to control of multiple monitors from a variable location.
- 8) Computer/Laptop used to set movement limits and obtain system status.

Benefits of an Orion Hazardous Area Monitor

The Orion hazardous area fire monitors use computer-controlled, motor-driven swivels for the most flexible remote control. The motor units are Hazardous area certified to ATEX and IECEx Exd for Class 1, Zone 1 areas.

Fully Adjustable Nozzle

Infinitely adjustable nozzle between full jet, and full spray.

Fully Enclosed Swivels

Protects the swivels from water and dirt ingress, prolonging product life

Automatic Parking (Optional Extra)

Monitor can be set to park automatically at the touch of a button

SS316L (Commando) or Bronze LG2 (Warden) Waterway

Ideal for use in both seawater and freshwater applications. Other materials are available on request.

Monitor Oscillation (Optional Extra)

Monitor can be set to automatically oscillate within user-determined limits.

Internal Sensors

All sensors internally located to protect them from damage

Corrosion Resistant

All external components are made of SS316 or Brass

Simple Maintenance Requirements

With fully enclosed swivels, annual maintenance requires only a grease gun.

Simple Wiring

Only 5 cores + Earth required

Armoured Cable

To protect cables from damage

IP66 Rated

Monitor is completely IP66 rated

Low Long Term Maintenance Costs

Corrosion resistant materials throughout, combined with very simple maintenance requirements result in many years of trouble free operation.

Reduced Installation Time

The system has been designed to provide the simplest installation possible. Each component is pre-wired, and only needs a minimal amount of cabling between them, decreasing material cost and installation time.

Automated Operation

The monitors can be programmed to perform a variety of automated movements at the touch of a switch, including automatic oscillation and automatic parking after use.

Expansion Capability

The system has been designed to easily accept future expansion requirements. (E.g. Additional control panels)

Adjustable Limit Setting

The monitors have a market leading operating range, and can be adjusted to have limit stops anywhere within the +/- 250° rotation range, or within the +90/-75° elevation range.

Impressive Fault-Finding Built-In

Built into the system is a unique fault-finding capability which identifies specific faults, reducing commissioning time and system downtime, as well as lowering maintenance costs.

Position Feedback

Each motor on the system gives feedback on its operating status and position. This can be monitored by a computer to give the operator a visual representation of the monitors behaviour.



Wide Movement Limits

Our electric monitor ranges have market-leading movement limits, creating a very versatile monitor that can work around your particular site requirements.

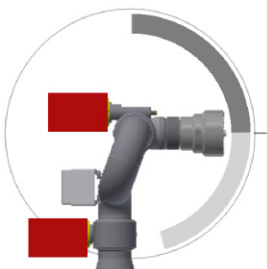

+90° and -75° of vertical movement



+250° and -250° of horizontal movement



Specifications

There are two standard options for use on the Orion Hazardous Area Monitor System, the Warden range of Bronze (LG2 or AB2) monitors, or the Commando range of Stainless Steel (SS316L). Both options are hazardous area certified to IECEx for Class 1, Zone 1 areas.



		Commando			Warden	
		3151 EX	4151 EX	6151 EX	3173 EX	4173 EX
Performance	Maximum Recommended Flow	4,500 lpm	7,500 lpm	15,000 lpm	4,500 lpm	7,500 lpm
	Throw Distance @ 700 kPa*	Up to 75m	Up to 90m	Up to 100m	Up to 75m	Up to 90m
	Horizontal Movement	-250° to +250°				
	Vertical Movement	-75° to +90°				
Materials	Waterway	316L Stainless Steel			Bronze LG2	
	Swivels	316L Stainless Steel			Bronze LG2	
	Inlet Flange	316L Stainless Steel			Bronze LG2	
	Balls	Brass				
	Grease Nipples	316L Stainless Steel				
	Fasteners	316L Stainless Steel				
	Motor Housing	Bronze LG2				
Dimensions	Inlet Connection	Flanged 80mm ANSI 150	Flanged 100mm ANSI 150	Flanged 150mm ANSI 150	80mm Flat Face Multi-Standard**	100mm Flat Face Multi-Standard**
	Outlet Connection	80mm BSP	100mm BSP	150mm BSP	80mm BSP	100mm BSP
	A (mm)	305	380	700	300	375
	B (mm)	385	465	545	340	420
	C (mm)	310	290	325	290	290
	Weight	36 kg	38 kg	75 kg	45 kg	48 kg

* The throw distance depends on the nozzle selection, flow and operating pressure, and is based on still-air conditions.

** Multi-Standard Flanges are suitable for use with Table E and ASME Class 150 connections.

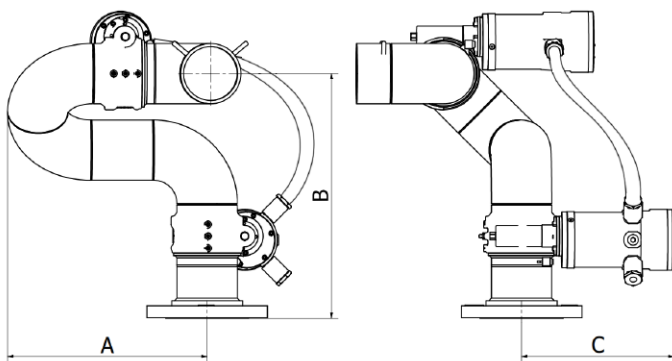

Typical Monitor Dimensions
(Actual waterway configuration may vary, nozzle not shown)

Bespoke Solutions



At Orion Fire, we have the ability to create a custom solution to meet your sites specialist requirements. Options relating to these monitors which you may consider are:

1) Custom Control Panel

A customised master control panel which incorporates more than one monitor control, as well as controls for other parts of the system (e.g. deluge valves, foam valves, foam pumps etc)

2) Computer Monitoring

A computer monitoring system which displays information such as current monitor position, valve output status, system pressures. It can also be used for fault-finding on the system, and for setting the oscillation and movement limits etc.



Orion Fire Engineering PTY LTD
26A Lyn Parade, Prestons
NSW 2170 AUSTRALIA
Tel: +61 2 9426 7900
www.orion-fire.com.au